

**Z8000** | **Series Advanced  
Vector Control Inverter**

User's Manual



- Thank you very much for your buying Z8000 series High-performance Vector Control Inverter.
- Before use, please read this manual thoroughly to ensure proper usage. Keep this manual at an easily accessible place so that can refer anytime as necessary.

### Safety Precautions

Please read this operation manual carefully before installation, operation, maintenance or inspection. In this manual, the safety precautions were sorted to "WARNING" or "CAUTION".



**WARNING**

Indicates a potentially dangerous situation which, if can not avoid will result in death or serious injury.



**CAUTION**

Indicates a potentially dangerous situation which, if can not avoid will cause minor or moderate injury and damage the device. This Symbol is also used for warning any un-safety operation.

In some cases, even the contents of "CAUTION" still can cause serious accident. Please follow these important precautions in any situation.

In some cases, even the contents of "CAUTION" still can cause serious accident. Please follow these important precautions in any situation.

In some cases, even the contents of "CAUTION" still can cause serious accident. Please follow these important precautions in any situation.

★ NOTE indicate the necessary operation to ensure the device run properly.

Warning Marks are placed on the front cover of the inverter.

Please follow these indications when using the inverter.

WARNING
<ul style="list-style-type: none"> <li>• May cause injury or electric shock.</li> <li>• Please follow the instructions in the manual before installation or operation.</li> <li>• Disconnect all power line before opening front cover of unit. Wait at least 10 minutes until DC Bus capacitors discharge.</li> <li>• Use proper grounding techniques.</li> <li>• Never connect AC power to output UVW terminals.</li> </ul>

## Contents

<b>Chapter 1 Introduction</b> .....	<b>1</b>
1.1 Technology Features .....	1
1.2 Description of Name Plate.....	4
1.3 Selection Guide .....	4
1.4 Inverter outline dimension drawings.....	7
1.5. INSPECTION .....	10
1.6. INSTALLATION .....	11
1.7 Environmental Requirement.....	11
1.8 Installation Space .....	13
<b>Chapter 2 Wiring</b> .....	<b>14</b>
2.1 Connection of Peripheral Devices .....	14
2.2 Terminal Configuration .....	15
2.2.1 Main Circuit Terminals .....	15
2.2.2 Control Circuit Terminals .....	16
2.3 Wiring Diagram.....	18
2.4 Wiring Main Circuits .....	18
2.4.1 Wiring at input side of main circuit.....	18
2.4.2 Wiring at inverter side of main circuit .....	19
2.4.3 Wiring at motor side of main circuit .....	20
2.4.4 Wiring of regenerative unit .....	20
2.4.5 Wiring of Common DC bus.....	21
2.4.6 Ground Wiring (PE).....	21

---

2.5 Installation Guidline to EMC Compliance .....	22
2.5.1 General knowledge of EMC .....	22
2.5.2 EMC features of inverter .....	22
2.5.3 EMC Installation Guideline .....	23
2.6 Peripheral Devices Specifications .....	25
<b>Chapter 3 Operation .....</b>	<b>27</b>
3.1 Keypad Description .....	26
3.2 Function key description.....	26
3.3 Indicator light description.....	27
3.4 Operation Process.....	27
3.4.1 Parameter setting.....	27
3.4.2 Fault reset .....	28
3.4.3 Motor parameter autotuning .....	28
3.5 Running State.....	29
3.5.1 Power-on initialization .....	29
3.5.2 Stand-by .....	29
3.5.3 Motor parameter autotuning .....	29
3.5.4 Operation.....	29
3.5.5 Fault .....	30
3.6 Quick Testing .....	30
<b>Chapter 4 Detailed Function Description .....</b>	<b>34</b>
<b>Chapter 5 Fault checking and ruled out.....</b>	<b>164</b>
5-1 Fault alarm and countermeasures .....	129
5.2 Common Faults and Solutions .....	134
<b>Chapter 6 Maintenance .....</b>	<b>173</b>
6.1 Inspection .....	137
6.2 Periodic Maintenance.....	138

<b>Chapter 7 Peripheral Devices Selection</b> .....	<b>176</b>
7-1 Peripheral Devices Description .....	140
7-2 Applied DC reactor Specification.....	141
7-3 Applied AC reactor Specification .....	142
7-4 Applied Braking resistor Specification .....	144
<b>Appendix A</b> .....	<b>181</b>
<b>Appendix B</b> .....	<b>224</b>

# Chapter 1 Introduction

## 1.1 Technology Features

Item		Z8000		
Standard functions	Control mode	Sensorless flux vector control (SFVC) Closed-loop vector control (CLVC) Voltage/Frequency (V/F) control		
	Maximum frequency	Vector control: 0–320 Hz V/F control: 0–3200Hz		
	Carrier frequency	1–16 kHz The carrier frequency is automatically adjusted based on the load features.		
	Input frequency resolution	Digital setting: 0.01 Hz Analog setting: maximum frequency x 0.025%		
	Startup torque	G type: 0.5 Hz/150% (SFVC); 0 Hz/180% (CLVC) P type: 0.5 Hz/100%		
	Speed range	1:100 (SFVC)	1:1000 (CLVC)	
	Speed stability accuracy	± 0.5% (SFVC)	± 0.02% (CLVC)	
	Torque control accuracy	± 5% (CLVC)		
	Overload capacity	G type: 80s for 150% of the rated current, 3s for 180% of the rated current. P type: 80s for 120% of the rated current, 3s for 150% of the rated current.		
	Torque boost	Fixed boost Customized boost 0.1%–30.0%		
	V/F curve	Straight-line V/F curve Multi-point V/F curve N-power V/F curve (1.2-power, 1.4-power, 1.6-power, 1.8-power, square)		
	V/F separation	Two types: complete separation; half separation		
	Ramp mode	Straight-line ramp S-curve ramp Four groups of acceleration/deceleration time with the range of 0.0–6500.0s		
DC braking	DC braking frequency: 0.00 Hz to maximum frequency Braking time: 0.0–100.0s Braking action current value: 0.0%–100.0%			

	Item	Z8000
Standard functions	JOG control	JOG frequency range: 0.00–50.00 Hz JOG acceleration/deceleration time: 0.0–6500.0s
	Onboard multiple preset speeds	It implements up to 16 speeds via the simple PLC function or combination of X terminal states
	Onboard PID	It realizes process-controlled closed loop control system easily.
	Auto voltage regulation (AVR)	It can keep constant output voltage automatically when the mains voltage changes.
	Overvoltage/ Overcurrent stall control	The current and voltage are limited automatically during the running process so as to avoid frequent tripping due to overvoltage/over current.
	Torque limit and control	It can limit the torque automatically and prevent frequent over current tripping during the running process.Torque control can be implemented in the CLVC mode.
Individualized functions	Support for multiple PG card	Support for rotating transformer PG card, differential input PG card, UVW differential input PG card, resolver PG card and OC input PG card
	Power dip ride through	The load feedback energy compensates the voltage reduction so that the AC drive can continue to run for a short time.
	Rapid current limit	It helps to avoid frequent over current faults of the AC drive.
	High performance	Control of asynchronous motor and synchronous motor are implemented through the high-performance current vector control technology.
	Timing control	Time range: 0.0–6500.0 minutes
	Communication methods	Modbus(standard), Profibus-DP(optional), CAN(optional)
Input and output	Input terminal	8 digital input terminals, one of which supports up to 100 kHz high-speed pulse input. 2 analog input terminals, one of which only supports 0–10 V voltage input and the other supports 0–10 V voltage input or 4–20 mA current input.
	Frequency source	Digital setting, analog voltage setting, analog current setting, pulse setting and serial communication port setting.

Item		Z8000
Input and output	Auxiliary frequency source	There are ten auxiliary frequency sources. It can implement fine tuning of auxiliary frequency and frequency synthesis.
	Running command source	Operation panel/Control terminals/Serial communication port You can perform switchover between these sources in various ways.
	Output terminal	1 high-speed pulse output terminal (open-collector) that supports 0–100 kHz square wave signal output 1 digital output terminal 2 relay output terminal 2 analog output terminal :that supports 0–20 mA current output or 0–10 V voltage output
operation on the operation panel	LED display	It displays the parameters.
	Key locking and function selection	It can lock the keys partially or completely and define the function range of some keys so as to prevent mis-function.
	Optional parts	Rotating transformer PG card, differential input PG card, UVW differential input PG card, resolver PG card and OC input PG card
Environment	Installation location	Indoor, free from direct sunlight, dust, corrosive gas, combustible gas, oil smoke, vapour, drip or salt.
	Altitude	Lower than 1000 m
	Ambient temperature	-10°C ~40°C (de-rated if the ambient temperature is between 40°C and 50°C)
	Humidity	Less than 95%RH, without condensing
	Vibration	Less than 5.9 m/s <sup>2</sup> (0.6 g)
	Storage temperature	-20°C~60°C

## 1.2 Description of Name Plate

### MODEL: Z8400-1R5G/2R2P

INPUT: 3PH 380V 50Hz/60Hz

OUTPUT: 3PH 380V 3.7/5.0

FREQ RANGE: 0.1-320Hz 1.5/2.2kW



14011311111

MODE: Z - 8 - 400 - 1R5G/2R2P

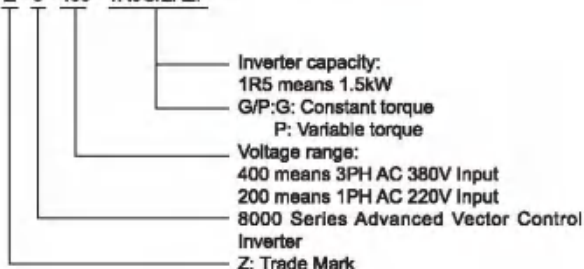

## 1.3 Selection Guide

1.3PH AC380V±15%/1PH AC220V±15%

Model	Rated Output Power (KW)	Rated Input current (A)	Rated Output Current (A)	Motor Power (kW)
1PH/3PH AC 220V -15%~15%				
Z8200-0R4G	0.4	5.4	2.5	0.4
Z8200-0R7G	0.75	7.2	5	0.75
Z8200-1R5G	1.5	10	7	1.5
Z8200-2R2G	2.2	16	11	2.2
Z8200-3R7G	3.7	23	16.5	3.7
3PH AC380V±15%				
Z8400-0R4G	0.4	3.4	1.2	0.4
Z8400-0R7G	0.75	3.8	2.5	0.75
Z8400-1R5G	1.5	5	3.7	1.5
Z8400-2R2G	2.2	5.8	5	2.2
Z8400-3R7G/5R5P	3.7/5.5	10/15	9/13	3.7/5.5
Z8400-5R5G/7R5P	5.5/7.5	15/20	13/17	5.5/7.5

Model	Rated Output Power (KW)	Rated Input current (A)	Rated Output Current (A)	Motor Power (kW)
Z8400-7R5G/11P	7.5/11	20/26	17/25	7.5/11
Z8400-11G/15P	11/15	26/35	25/32	11/15
Z8400-15G/18.5P	15/18.5	35/38	32/37	15/18.5
Z8400-18.5G/22P	18.5/22	38/46	37/45	18.5/22
Z8400-22G/30P	22/30	46/62	45/60	22/30
Z8400-30G/37P	30/37	62/76	60/75	30/37
Z8400-37G/45P	37/45	76/90	75/90	37/45
Z8400-45G/55P	45/55	90/105	90/110	45/55
Z8400-55G	55	105	110	55
Z8400-75P	75	140	150	75
Z8400-75G/90P	75/90	140/160	150/176	75/90
Z8400-90G/110P	90/110	160/210	176/210	90/110
Z8400-110G/132P	110/132	210/240	210/253	110/132
Z8400-132G/160P	132/160	240/290	253/300	132/160
Z8400-160G/185P	160/185	290/330	300/340	160/185
Z8400-185G/200P	185/200	330/370	340/380	185/200
Z8400-200G/220P	200/220	370/410	380/420	200/220
Z8400-220G/250P	220/250	410/460	420/470	220/250
Z8400-250G/280P	250/280	460/500	470/520	250/280
Z8400-280G/315P	280/315	500/580	520/600	280/315
Z8400-315G/350P	315/350	580/620	600/640	315/350
Z8400-350G/400P	350/400	620/670	640/690	350/400
Z8400-400G/450P	400/450	670/790	690/790	400/450
Z8400-450G/500P	450/500	790/835	790/860	450/500
Z8400-500G/560P	500/560	835/920	860/950	500/560
Z8400-560G/630P	560/630	920/1050	950/1100	560/630
Z8400-630G/710P	630/710	1050/1126	1100/1280	630/710
Z8400-710G/800P	710/800	1126/1460	1280/1380	710/800
Z8400-800G/900P	800/900	1460/1640	1380/1640	800/900
Z8400-900G/1000P	900/1000	1640/1800	1640/1720	900/1000
Z8400-1000G	1000	1800	1720	1000

## 2.3PH AC860V±15%

Model	Rated Output Power (kW)	Rated Output Current (A)	Outline dimension(mm)			Installation size(mm)	Remark
			length	width	height		
Z8600-11G/15P	11	16	410	277	189	390*262*Φ6.5	Wall-mounted
Z8600-15G/18D5P	15	20					
Z8600-18GD5/22P	18.5	25					
Z8600-22G/30P	22	28					
Z8600-30G/37P	30	35					
Z8600-37G/45P	37	45					
Z8600-45G/55P	45	52					
Z8600-55G/75P	55	63	595	300	236	573*200*Φ9	
Z8600-75G/90P	75	86					
N Z8600-90G/110P	90	98					
Z8600-110G/132P	110	121	620	380	290	595*250*Φ9	
Z8600-132G/160P	132	150					
Z8600-160G/185P	160	175	880	380	358	840*250*Φ13	
Z8600-185G/200P	185	198					
Z8600-200G/220P	200	218					
Z8600-220G/250P	220	240					
Z8600-250G/280P	250	270					
Z8600-280G/315P	280	320	995	630	350	971*500*Φ11	
Z8600-315G/350P	315	350					
Z8600-350G/400P	350	380					

Model	Rated Output Power (kW)	Rated Output Current (A)	Outline dimension(mm)			Installation size(mm)	Remark
			length	width	height		
Z8600-400G/450P	400	430	Wall-mounted: 1040 Cabinet: 1515	680	400	Wall-mounted: 1016*520*Φ11 Cabinet: 550*300*Φ13	Wall-mounted/ Cabinet
Z8600-450G/500P	450	480					
Z8600-500G/560P	500	540					
Z8600-560G/630P	560	600	1800	650	920	550*800*Φ17	Cabinet
Z8600-630G/710P	630	680					
Z8600-710G/800P	710	750	1800	750	920	650*800*Φ17	
Z8600-800G/900P	800	860					
Z8600-900G /1000P	900	950	1800	900	920	800*800*Φ17	
Z8600-1000P	1000	1080					

## 1.4 Inverter outline dimension drawings

### (1) wall-mounted

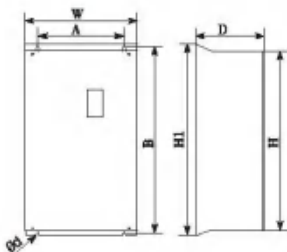

## (2) cabinet installation

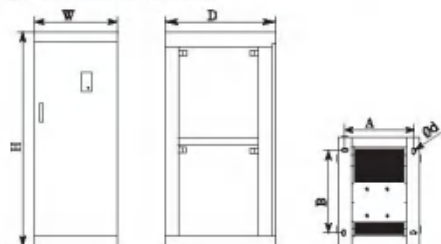

Unit: mm

Model	Outline dimension				Installation size A*B*Φd	Unit: mm	
	W	H	H1	D		Installation	Remark
Z8200-0R4G	125	170	—	140	117*160*Φ5	Wall-mounted	All plastic
Z8200-0R7G							
Z8200-1R5G							
Z8200-2R2G							
Z8200-3R7G	120	225	—	143	105*208*Φ5		Semi plastic
Z8400-0R4G	125	170	—	140	117*160*Φ5		All plastic
Z8400-0R7G							
Z8400-1R5G							
Z8400-2R2G							
Z8400-3R7G/5R5P	120	225	—	143	105*208*Φ5		Semi plastic
Z8400-5R5G/7R5P	185	260	—	170	168*248*Φ6.5	All plastic	
Z8400-7R5G/11P							
Z8400-11G/15P	210	330	—	190	195*310*Φ6.5	Semi plastic	
Z8400-15G/18.5P							

Model	Outline dimension				Installation size A*B*Φd	Unit: mm	
	W	H	H1	D		Installation	Remark
Z8400-18.5G/22P	277	410	—	189	262*390*6.5	Wall-mounted	Iron shell
Z8400-22G/30P							
Z8400-30G/37P							
Z8400-37G-NN							
Z8400-37G/45P	300	430	455	212	200*433*Φ9		
Z8400-45G/55P	300	535	560	236	200*538*Φ9		
Z8400-55G							
Z8400-75P							
Z8400-75G/90P1	338	548	578	256.5	270*560*Φ9		New
Z8400-90G/110P1	338	550	580	300	270*564*Φ9		
Z8400-110G/132P1							
Z8400-132G/160P	420	Wall-mounted: 730	Wall-mounted: 790	330	Wall-mounted: 300*765*Φ11	Wall-mounted or cabinet	Iron shell
Z8400-160G/185P		Cabinet: 1130	Cabinet: 1165		Cabinet: 250*350*Φ12		
Z8400-185G/200P	530	Wall-mounted: 800	Wall-mounted: 860	335	Wall-mounted: 400*835*Φ11		
Z8400-200G/220P		Cabinet: 1300	Cabinet: 1335		Cabinet: 250*450*Φ12		
Z8400-220G/250P							

Model	Outline dimension				Installation size A*B*Φd	Unit: mm	
	W	H	H1	D		Installation	Remark
Z8400-250G/280P	700	Wall-mounted: 880 Cabinet: 1380	Wall-mounted: 940 Cabinet: 1415	350	Wall-mounted: 600*915*Φ11 Cabinet: 250*620*Φ12	Wall-mounted or cabinet	Iron shell cabinet
Z8400-280G/315P							
Z8400-315G/350P							
Z8400-350G/400P	600	1600	—	800	550*700*Φ13	cabinet	
Z8400-400G/450P							
Z8400-450G/500P							
Z8400-500G/560P	650	1600	—	800	600*700*Φ13	cabinet	
Z8400-560G/630P							
Z8400-630G/710P							
Z8400-710G/800P	700	2200	—	1000	650*900*Φ13	cabinet	
Z8400-800G/900P							
Z8400-900G/1000P							
Z8400-1000G							

## 1.5. INSPECTION



### CAUTION

•Don't install or use any inverter that is damaged or have fault part, otherwise may cause injury.

Check the following items when unpacking the inverter,

1. Inspect the entire exterior of the Inverter to ensure there are no scratches or other damage caused by the transportation.
2. Ensure there is operation manual and warranty card in the packing box.
3. Inspect the nameplate and ensure it is what you ordered.

4. Ensure the optional parts are what you need if have ordered any optional parts.  
Please contact the local agent if there is any damage in the inverter or optional parts.

 **WARNING**

- The person without passing the training manipulate the device or any rule in the "Warning" being violated, will cause severe injury or property loss. Only the person, who has passed the training on the design, installation, commissioning and operation of the device and gotten the certification, is permitted to operate this equipment.
- Input power cable must be connected tightly, and the equipment must be grounded securely.
- Even if the inverter is not running, the following terminals still have dangerous voltage:
  - Power Terminals: R, S, T
  - Motor Connection Terminals: U, V, W.
- When power off, should not install the inverter until 5 minutes after, which can ensure the device discharge completely.
- The section area of grounding conductor must be no less than that of power supply cable.

 **CAUTION**

- When moving the inverter please lift by its base and don't lift by the panel. Otherwise may cause the main unit fall off which may result in personal injury.
- Install the inverter on the fireproofing material (such as metal) to prevent fire.
- When need install two or more inverters in one cabinet, cooling fan should be provided to make sure that the air temperature is lower than 45°C. Otherwise it could cause fire or damage the device.

## 1.6. INSTALLATION

### 1.7 Environmental Requirement

#### 1. Temperature

Environment temperature range: -10°C ~ +40°C. Inverter will be derated if ambient temperature exceeds 40°C.

#### 2. Humidity

Less than 95% RH, without dewfall.

### 3. Altitude

Inverter can output the rated power when installed with altitude of lower than 1000m. It will be derated when the altitude is higher than 1000m. For details, please refer to the following figure:

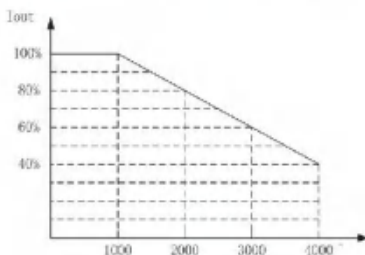

Figure 3.1 Relationship between output current and altitude.

### 4. Impact and Vibration

It is not allowed that the inverter falls down or suffers from fierce impact or the inverter installed at the place that vibration frequently.

### 5. Electromagnetic Radiation

Keep away from the electromagnetic radiation source.

### 6. Water

Do not install the inverter at the wringing or dewfall place.

### 7. Air Pollution

Keep away from air pollution such as dusty, corrosive gas.

### 8. Storage

Do not store the inverter in the environment with direct sunlight, vapor, oil fog and vibration.

## 1.8 Installation Space

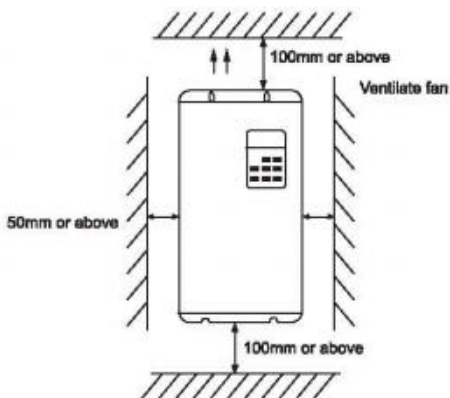

### Safe space

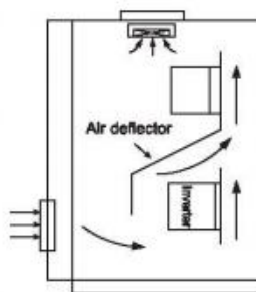

Installation of multiple inverters.

Notice: Add the air deflector when apply the up-down installation.

## Chapter 2 Wiring

### 2.1 Connection of Peripheral Devices

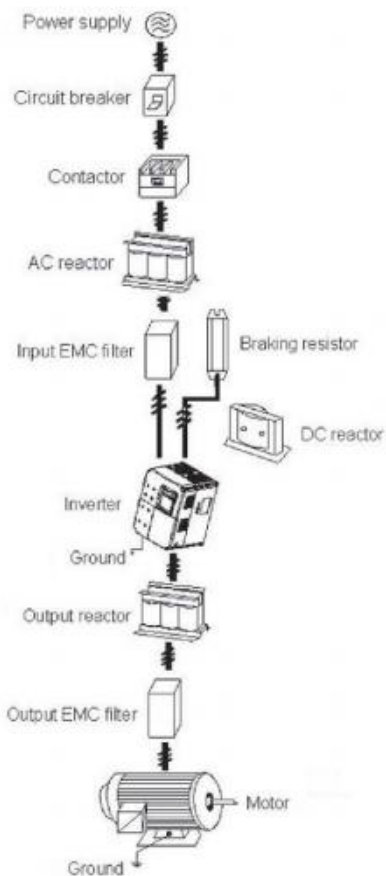

## 2.2 Terminal Configuration

### 2.2.1 Main Circuit Terminals

1. Main circuit terminals (3PH AC 380V 0.75~3.7kW ).

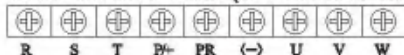

2. Main circuit terminals (3PH AC 380V 5.5~7.5kW ).

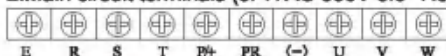

3. Main circuit terminals (3PH AC 380V 11~15kW ).

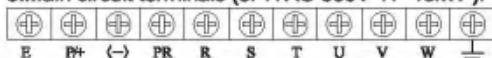

4. Main circuit terminals (3PH AC 380V 18.5~30kW ).



5. Main circuit terminals (3PH AC 380V 37~55kW The brake unit is built-in).

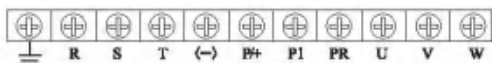

6. Main circuit terminals (3PH AC 380V 75kW)

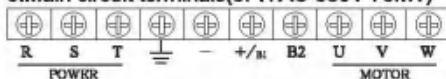

7. Main circuit terminals (3PH AC 380V 90~110kW ).



8. Main circuit terminals (3PH AC 380V 132~315kW ).



### 9. Main circuit terminals (3PH AC 380V 350kW or more)

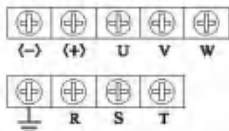

NOTE: "710–1000kW ,Top row, the front door wiring, Second row from the back door wiring "

Main circuit terminal functions are summarized according to the terminal symbols in the following table. Wire the terminal correctly for the desired purposes.

Terminal Symbol	Description
R, S, T	Terminals of 3 phase AC input
P, (-)	Spare terminals of external braking unit
P, Pr	Spare terminals of external braking resistor
P1, P/+	Spare terminals of external DC reactor
(-)	Terminal of negative DC bus
U, V, W	Terminals of 3 phase AC output
⏚	Terminal of ground

### 2.2.2 Control Circuit Terminals



Terminal	Description
X1–X4, X6–X8	ON-OFF signal input, optical coupling with PLC and COM Input voltage range: 9–30V Input impedance: 3.3kΩ
X5	High speed pulse or ON-OFF signal input, optical coupling with PLC and COM. Pulse input frequency range: 0–50kHz Input voltage range: 9–30V Input impedance: 1.1kΩ
PLC	x ternal power supply. +24V terminal is connected to PLC terminal as default setting. If user need external power supply, disconnect +24V terminal with PW terminal and connect PLC
+24V	terminal with external power supply. Provide output power supply of +24V. Maximum output current: 150mA
FIV	Analog input, -10V–10V Input impedance: 20kΩ

Terminal	Description
FIC	Analog input, 0~10V/ 0~20mA, switched by J3. Input impedance: 10k $\Omega$ (voltage input) / 250 $\Omega$ (current input)
GND	Common ground terminal of analog signal and +10V. GND must be isolated from COM.
+10V	Supply +10V for inverter. High speed pulse output terminal. The corresponding common ground terminal is COM.
YO	Output frequency range: 0~50 kHz
COM	Common ground terminal for digital signal and +24V (or external power supply).
FOV/FOC	Provide voltage or current output which can be switched by J4 and J1. Output range: 0~10V/ 0~20mA
RA/RB/RC	Relay output: RC—common; RB—NC; RA—NO (Optional) Contact capacity: AC 250V/3A, DC 30V/1A.
YA/YB/YC	Relay output: YC—common; YB—NC; YA—NO. Contact capacity: AC 250V/3A, DC 30V/1A.
RS+,RS-	485 communication port. 485 differential signal, +, -.

## 2.3 Wiring Diagram

### Typical Wiring Diagram

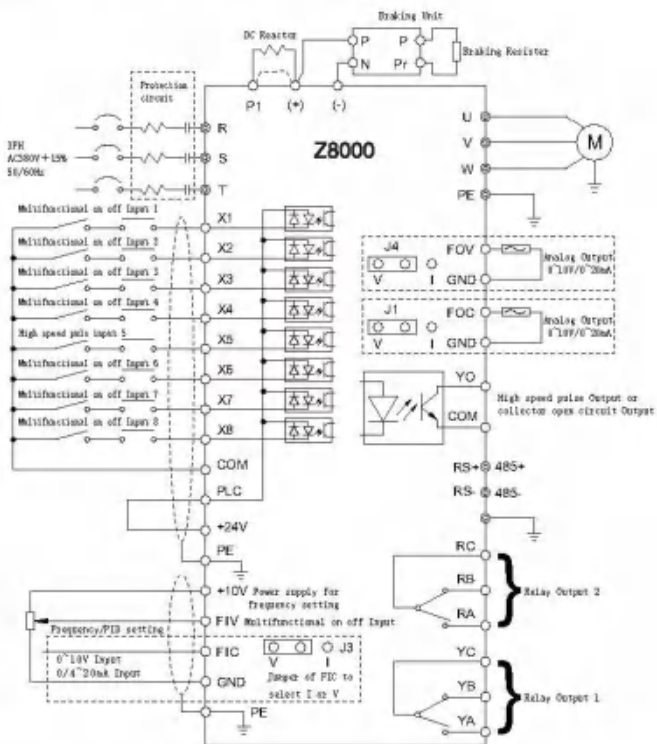

## 2.4 Wiring Main Circuits

### 2.4.1 Wiring at Input side of main circuit

#### 2.4.1.1 Circuit breaker

It is necessary to connect a circuit breaker which is compatible with the capacity of inverter between 3ph AC power supply and power input terminals (R, S, T). The capacity of breaker is 1.5-2 times to the rated current of inverter. For details, see <Specifications of Breaker, Cable, and Contactor>.

### 2.4.1.2 Contactor

In order to cut off the input power effectively when something is wrong in the system, contactor should be installed at the input side to control the ON-OFF of the main circuit power supply.

### 2.4.1.3 AC reactor

In order to prevent the rectifier damage result from the large current, AC reactor should be installed at the input side. It can also prevent rectifier from sudden variation of power voltage or harmonic generated by phase-control load.

### 2.4.1.4 Input EMC filter

The surrounding device may be disturbed by the cables when the inverter is working. EMC filter can minimize the interference. Just like the following figure.

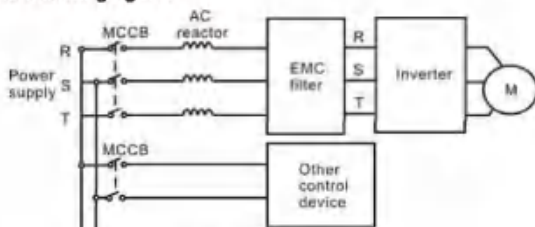

Wiring at input side.

## 2.4.2 Wiring at inverter side of main circuit

### 2.4.2.1 DC reactor

Inverters above 250kW have built-in DC reactor which can improve the power factor,

### 2.4.2.2 Braking unit and braking resistor

- Inverter of 15KW and below have built-in braking unit. In order to dissipate the regenerative energy generated by dynamic braking, the braking resistor should be installed at (+) and Pr terminals. The wire length of the braking resistor should be less than 5m.

- Inverter of 18.5KW and above need connect external braking unit which should be installed at (+) and (-) terminals. The cable between inverter and braking unit should be less than 5m. The cable between braking unit and braking resistor should be less than 10m.

- The temperature of braking resistor will increase because the regenerative energy will be transformed to heat. Safety protection and good ventilation is recommended.

Notice: Be sure that the electric polarity of (+) (-) terminals is right; it is not allowed to connect (+) with (-) terminals directly, Otherwise

damage or fire may occur.

### 2.4.3 Wiring at motor side of main circuit

#### 2.4.3.1 Output Reactor

Output reactor must be installed in the following condition. When the distance between inverter and motor is more than 50m, inverter may be tripped by over-current protection frequently because of the large leakage current resulted from the parasitic capacitance with ground. And the same time to avoid the damage of motor insulation, the output reactor should be installed.

#### 2.4.3.2 Output EMC filter

EMC filter should be installed to minimize the leakage current caused by the cable and minimize the radio noise caused by the cables between the inverter and cable. Just see the following figure.

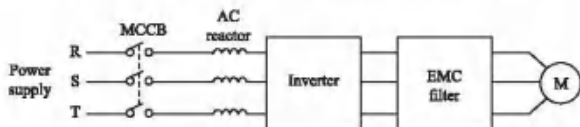

Wiring at motor side.

### 2.4.4 Wiring of regenerative unit

Regenerative unit is used for putting the electricity generated by braking of motor to the grid. Compared with traditional 3 phase inverse parallel bridge type rectifier unit, regenerative unit uses IGBT so that the total harmonic distortion (THD) is less than 4%. Regenerative unit is widely used for centrifugal and hoisting equipment.

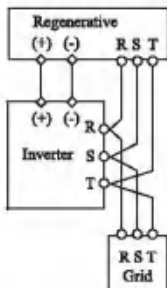

Wiring of regenerative unit.

### 2.4.5 Wiring of Common DC bus

Common DC bus method is widely used in the paper industry and chemical fiber industry which need multi-motor to coordinate. In these applications, some motors are in driving status while some others are in regenerative braking (generating electricity) status. The regenerated energy is automatically balanced through the common DC bus, which means it can supply to motors in driving status. Therefore the power consumption of whole system will be less compared with the traditional method (one inverter drives one motor).

When two motors are running at the same time (i.e. winding application), one is in driving status and the other is in regenerative status. In this case the DC buses of these two inverters can be connected in parallel so that the regenerated energy can be supplied to motors in driving status whenever it needs. Its detailed wiring is shown in the following figure:

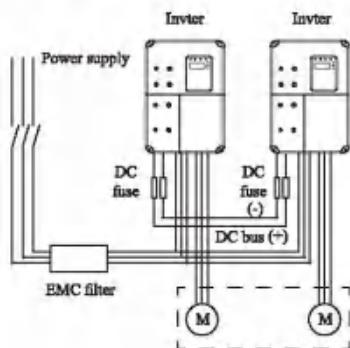

Wiring of common DC bus.

**Notice: Two Inverters must be the same model when connected with Common DC bus method. Be sure they are powered on at the same time.**

### 2.4.6 Ground Wiring (PE)

In order to ensure safety and prevent electrical shock and fire, terminal PE must be grounded with ground resistance. The ground wire should be big and short, and it is better to use copper wire (>3.5mm<sup>2</sup>). When multiple inverters need to be grounded, do not loop the ground wire.

## **2.5 Installation Guidline to EMC Compliance**

### **2.5.1 General knowledge of EMC**

EMC is the abbreviation of electromagnetic compatibility, which means the device or system has the ability to work normally in the electromagnetic environment and will not generate any electromagnetic interference to other equipments.

EMC includes two subjects: electromagnetic interference and electromagnetic anti-jamming.

According to the transmission mode, Electromagnetic interference can be divided into two categories: conducted interference and radiated interference. Conducted interference is the interference transmitted by conductor. Therefore, any conductors (such as wire, transmission line, inductor, capacitor and so on) are the transmission channels of the interference.

Radiated interference is the interference transmitted in electromagnetic wave, and the energy is inverse proportional to the square of distance.

Three necessary conditions or essentials of electromagnetic interference are: interference source, transmission channel and sensitive receiver. For customers, the solution of EMC problem is mainly in transmission channel because of the device attribute of disturbance source and receiver can not be changed.

### **2.5.2 EMC features of inverter**

Like other electric or electronic devices, inverter is not only an electromagnetic interference source but also an electromagnetic receiver. The operating principle of inverter determines that it can produce certain electromagnetic interference noise. At the same time inverter should be designed with certain anti-jamming ability to ensure the smooth working in certain electromagnetic environment. Following is its EMC features:

2.5.2.1 Input current is non-sine wave. The input current includes large amount of high-harmonic waves that can cause electromagnetic interference, decrease the grid power factor and increase the line loss.

2.5.2.2 Output voltage is high frequency PMW wave, which can increase the temperature rise and shorten the life of motor. And the leakage current will also increase, which can lead to the leakage protection device malfunction and generate strong electromagnetic interference to influence the reliability of other electric devices.

2.5.2.3 As the electromagnetic receiver, too strong interference will damage the inverter and influence the normal using of customers.

2.5.2.4 In the system, EMS and EMI of inverter coexist. Decrease the EMI of inverter can increase its EMS ability.

### 2.5.3 EMC Installation Guideline

In order to ensure all electric devices in the same system to work smoothly, this section, based on EMC features of inverter, introduces EMC installation process in several aspects of application (noise control, site wiring, grounding, leakage current and power supply filter). The good effective of EMC will depend on the good effective of all of these five aspects.

#### 2.5.3.1 Noise control

All the connections to the control terminals must use shielded wire. And the shield layer of the wire must ground near the wire entrance of inverter. The ground mode is 360 degree annular connection formed by cable clips. It is strictly prohibitive to connect the twisted shielding layer to the ground of inverter, which greatly decreases or loses the shielding effect.

Connect inverter and motor with the shielded wire or the separated cable tray. One side of shield layer of shielded wire or metal cover of separated cable tray should connect to ground, and the other side should connect to the motor cover. Installing an EMC filter can reduce the electromagnetic noise greatly.

#### 2.5.3.2 Site wiring

Power supply wiring: the power should be separated supplied from electrical transformer. Normally it is 5 core wires, three of which are fire wires, one of which is the neutral wire, and one of which is the ground wire. It is strictly prohibitive to use the same line to be both the neutral wire and the ground wire. Device categorization: there are different electric devices contained in one control cabinet, such as inverter, filter, PLC and instrument etc, which have different ability of emitting and withstanding electromagnetic noise. Therefore, it needs to categorize these devices into strong noise device and noise sensitive device. The same kinds of device should be placed in the same area, and the distance between devices of different category should be more than 20cm. Wire Arrangement inside the control cabinet: there are signal wire (light current) and power cable (strong current) in one cabinet. For the inverter, the power cables are categorized into input cable and output cable, Signal wires can be easily disturbed by power cables to make the equipment malfunction. Therefore when wiring, signal cables and power cables should be arranged in different area. It is strictly prohibitive to arrange them in parallel or interlacement at a close distance (less than 20cm) or tie them together. If the signal wires have to cross the

power cables, they should be arranged in 90 angles. Power input and output cables should not either be arranged in interlacement or tied together, especially when installed the EMC filter. Otherwise the distributed capacitances of its input and output power cable can be coupling each other to make the EMC filter out of function.

#### 2.5.3.3 Ground

Inverter must be ground safely when in operation. Grounding enjoys priority in all EMC methods because it does not only ensure the safety of equipment and persons, but also is the simplest, most effective and lowest cost solution for EMC problems. Grounding has three categories: special pole grounding, common pole grounding and series-wound grounding. Different control system should use special pole grounding, and different devices in the same control system should use common pole grounding, and different devices connected by same power cable should use series-wound grounding.

#### 2.5.3.4 Leakage Current

Leakage current includes line-to-line leakage current and over-ground leakage current. Its value depends on distributed capacitances and carrier frequency of inverter. The over-ground leakage current, which is the current passing through the common ground wire, can not only flow into inverter system but also other devices. It also can make leakage current circuit breaker, relay or other devices malfunction. The value of line-to-line leakage current, which means the leakage current passing through distributed capacitors of input output wire, depends on the carrier frequency of inverter, the length and section areas of motor cables. The higher carrier frequency of inverter, the longer of the motor cable and/or the bigger cable section area, the larger leakage current will occur.

Countermeasure: Decreasing the carrier frequency can effectively decrease the leakage current. In the case of motor cable is relatively long (longer than 50m), it is necessary to install AC reactor or sinusoidal wave filter at the output side, and when it is even longer, it is necessary to install one reactor at every certain distance.

#### 2.5.3.5 EMC Filter

EMC filter has a great effect of electromagnetic decoupling, so it is preferred for customer to install it.

For inverter, noise filter has following categories:

- Noise filter installed at the input side of inverter;
- Install noise isolation for other equipment by means of isolation transformer or power filter.

## 2.6 Peripheral Devices Specifications

Applicable Inverter Type	Input Voltage	Motor Output (kW)	Main Circuit Cable Type(mm <sup>2</sup> )	Breaker Selection (A)	Input Side Magnetic Contrator
Z8200-0R4G	220V	0.4	0.75	10	9
Z8200-0R7G	220V	0.75	0.75	16	12
Z8200-1R5G	220V	1.5	1.5	25	18
Z8200-2R2G	220V	2.2	2.5	32	25
Z8200-3R7G	220V	3.7	2.5	40	32
Z8400-0R4G	380V	0.4	0.75	6	9
Z8400-0R7G	380V	0.75	0.75	6	9
Z8400-1R5G	380V	1.5	0.75	10	9
Z8400-2R2G	380V	2.2	0.75	10	9
Z8400-3R7G/5R5P	380V	3.7/5.5	1.5	16	12
Z8400-5R5G/7R5P	380V	5.5/7.5	2.5	20	18
Z8400-7R5G/11P	380V	7.5/11	4	32	25
Z8400-11G/15P	380V	11.0/15	4	40	32
Z8400-15G/18.5P	380V	15/18.5	6	50	38
Z8400-18.5G/22P	380V	18.5/22	10	50	40
Z8400-22G/30P	380V	22/30	10	63	50
Z8400-30G/37P	380V	30/37	16	100	65
Z8400-37G/45P	380V	37/45	25	100	80
Z8400-45G/55P	380V	45/55	35	125	95
Z8400-55G/75P	380V	55/75	50	160	115
Z8400-75G/90P	380V	75/90	70	225	170
Z8400-90G/110P	380V	90/110	95	250	170
Z8400-110G/132P	380V	110/132	120	400	205
Z8400-132G/160P	380V	132/160	150	400	245
Z8400-160G/185P	380V	160/185	185	400	300
Z8400-185G/200P	380V	185/200	185	500	410
Z8400-200G/220P	380V	200/220	185	500	410
Z8400-220G/250P	380V	220/250	240	630	410
Z8400-250G/280P	380V	250/280	240	630	475
Z8400-280G/315P	380V	280/315	150*2	700	620
Z8400-315G/350P	380V	315/350	185*2	800	620
Z8400-350G/400P	380V	350/400	185*2	800	620
Z8400-400G/450P	380V	400/450	240*2	1000	800
Z8400-450G/500P	380V	450/500	240*2	1000	800
Z8400-500G/560P	380V	500/560	185*3	1600	1000
Z8400-560G/630P	380V	560/630	185*3	1600	1000
Z8400-630G/710P	380V	630/710	240*3	1600	1250
Z8400-710G/800P	380V	710/800	240*3	2000	1250
Z8400-800G/900P	380V	800/900	240*3	2000	1600
Z8400-900G/1000P	380V	900/1000	240*3	2500	1600
Z8400-1000G	380V	1000	240*3	2500	2000

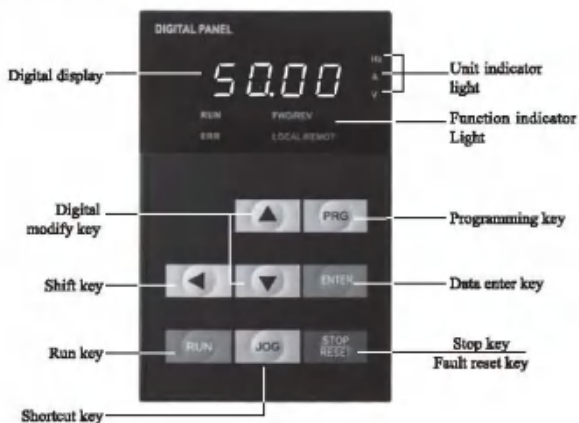

## Chapter 3 Operation

### 3.1 Keypad Description



### 3.2 Function key description

Key	Name	Description
	Programming key	Entry or escape of first-level menu
	Data enter key	Progressively enter menu and confirm parameters.
	UP Increment Key	Progressively increase data or function codes.
	DOWN Decrement Key	Progressive decrease data or function codes.
	Right shift Key	In parameter setting mode, press this button to select the bit to be modified. In other modes, cyclically displays parameters by right shift
	Run key	Start to run the inverter in keypad control mode.

Key	Name	Description
	Stop key/Fault reset key	In running status, restricted by F7.04, can be used to stop the inverter. When fault alarm, can be used to reset the inverter without any restriction.
	Shortcut Key	Determined by Function Code F7.03: 0: Display status switching 1: Jog operation 2: Switch between forward and reverse 3: Clear the UP/DOWN settings. 4: Quick debugging mode
	Combination Key	Pressing the RUN and STOP/RST at the same time can achieve inverter coast to stop.

### 3.3 Indicator light description

#### 1) Function Indicator Light Description

Indicator Light Name	Indicator Light Description
FWD/REV	Extinguished: forward operation Light on: reverse operation.
LOCAL/REMOT	Extinguished: keypad control Flickering: terminal control Light on: communication control

#### 2) Unit Indicator Light Description

Symbol	Description
Hz	Frequency unit
A	Current unit
V	Voltage unit

#### 3) Digital Display

Have 5 digit LED, which can display all kinds of monitoring data and alarm codes such as reference frequency, output frequency and so on.

### 3.4 Operation Process

#### 3.4.1 Parameter setting

Three levels of menu are:

1. Function code group (first-level);
2. Function code (second-level);
3. Function code value (third-level).

Remarks:

Press both the PRG and the ENTER can return to the second-class menu from the third-class menu. The difference is: pressing

PRG will save the set parameters into the control panel, and then return to the second-class menu with shifting to the next function code automatically; while pressing ENTER will directly return to the second-class menu without saving the parameters, and keep staying at the current function code.

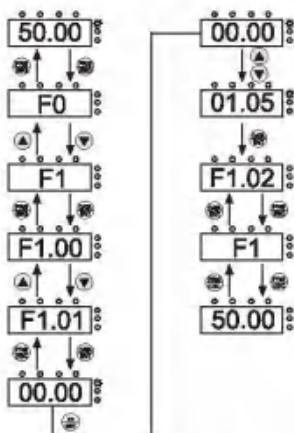

Flow chart of parameter setting.

Under the third-class menu, if the parameter has no flickering bit, it means the function code cannot be modified. The possible reasons could be:

- 1) This function code is not modifiable parameter, such as actual detected parameter, operation records and so on;
- 2) This function code is not modifiable in running status, but modifiable in stop status

### 3.4.2 Fault reset

If the inverter has fault, it will prompt the related fault information. User can use STOP or according terminals determined by P5 Group to reset the fault. After fault reset, the inverter is at stand-by state. If user does not reset the inverter when it is at fault state, the inverter will be at operation protection state, and can not run.

### 3.4.3 Motor parameter autotuning

If "Sensorless Vector Control" mode is chosen, motor nameplate parameters must be input correctly as the autotuning is based on it. The performance of vector control depends on the parameters of motor strongly, so to achieve excellent performance, firstly must

obtain the parameter of motor exactly. The procedure of motor parameter autotuning is as follows:

Firstly, choose the keypad command channel as the operation command channel (P0.02).

And then input following parameters according to the actual motor parameters:

P2.01: motor rated power.

P2.02: motor rated frequency;

P2.03: motor rated speed;

P2.04: motor rated voltage;

P2.05: motor rated current

Notice: the motor should be uncoupled with its load; otherwise, the motor parameters obtained by autotuning may be not correct.

### 3.5 Running State

#### 3.5.1 Power-on initialization

Firstly the system initializes during the inverter power-on, and LED displays "8000". After the initialization is completed, the inverter is on stand-by status.

#### 3.5.2 Stand-by

At stop or running status, parameters of multi-status can be displayed. Whether or not to display this parameter can be chosen through Function Code P7.03(Running status display selection )

And P7.05(Stop status display selection) according to binary bits, the detailed description of each bit please refer the function code description of P7.03 and P7.05.

In stop status, there are nine parameters which can be chosen to display or not. They are: reference frequency, DC bus voltage, ON-OFF input status, open collector output status, PID setting, PID feedback, analog input FIV voltage, analog input FIC voltage, step number of multi-step speed. Whether or not to display can be decided by setting the corresponding binary bit of P7.05 Press the to scroll through the parameters in right order. Press JOG to scroll through the parameters in left order.

#### 3.5.3 Motor parameter autotuning

For details, please refer to the description of P2.37.

#### 3.5.4 Operation

In running status, there are fourteen running parameters: output frequency, reference frequency, DC bus voltage, output voltage, output current, output power, output torque, PID setting, PID

feedback, ON-OFF input status, open collector output status, length value, count value, step number of PLC and multi-step speed, voltage of FIV, voltage of FIV and step number of multi-step speed. Whether or not to display can be decided by the bit option of Function Code P7.03, P7.04 (converted into binary system). Press the to scroll through the parameters in right order . Press JOG to scroll through the parameters in left order.

### 3.5.5 Fault

Z8000 series inverter offers a variety of fault information. For details, see inverter faults and their troubleshooting.

### 3.6 Quick Testing

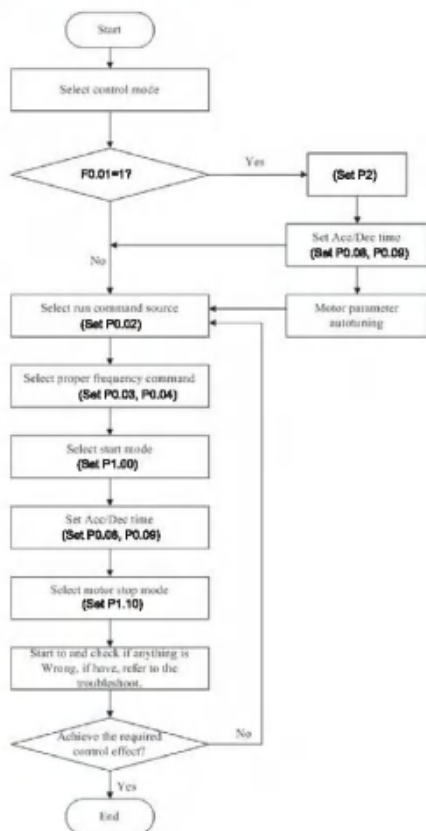

## Chapter 4

### Detailed Function Description

#### Group P0: Basic Parameters

P0.00	G/P type display	Default	Model dependent	
	Setting Range	1	G type (constant torque load)	
		2	P type (variable torque load e.g. fan and pump)	

This parameter is used to display the delivered model and cannot be modified.

1: Applicable to constant torque load with rated parameters specified

2: Applicable to variable torque load (fan and pump) with rated parameters specified

P0.01	Control mode selection	Default	0
	Setting Range	0	Voltage/Frequency (V/F) control
1		Sensorless flux vector control (SFVC)	
2		Closed-loop vector control (CLVC)	

#### 0: Voltage/Frequency (V/F) control

It is applicable to applications with low load requirements or applications where one AC drive operates multiple motors, such as fan and pump

#### 1: Sensorless flux vector control (SFVC)

It indicates open-loop vector control, and is applicable to high-performance control applications such as machine tool, centrifuge, wire drawing machine and injection moulding machine. One AC drive can operate only one motor.

#### 2: Closed-loop vector control (CLVC)

It is applicable to high-accuracy speed control or torque control applications such as high-speed paper making machine, crane and elevator. One AC drive can operate only one motor. An encoder must be installed at the motor side, and a PG card matching the encoder must be installed at the AC drive side.

Note: If vector control is used, motor auto-tuning must be performed because the advantages of vector control can only be utilized after correct motor parameters are obtained. Better performance can be achieved by adjusting speed regulator parameters in group P2

For the permanent magnetic synchronous motor (PMSM), the

Z8000 does not support SFVC. CLVC is used generally. In some low-power motor applications, you can also use V/F.

P0.02	Command source selection		Default	0
	Setting Range	0	Operation panel control (LED off)	
		1	Terminal control (LED on)	
		2	Communication control (LED blinking)	

It is used to determine the input channel of the AC drive control commands, such as run, stop, forward rotation, reverse rotation and jog operation. You can input the commands in the following three channels:

0: Operation panel control ("LOCAL/REMOT" indicator off)

Commands are given by pressing keys RUN and STOP/RES on the operation panel.

1: Terminal control ("LOCAL/REMOT" indicator on)

Commands are given by means of multifunctional input terminals with functions such as FWD, REV, JOGF, and JOGR.

2: Communication control ("LOCAL/REMOT" indicator blinking)

Commands are given from host computer. If this parameter is set to 2, a communication card (Modbus RTU, PROFIBUS-DP card, CAN link card, user programmable card or CAN card) must be installed.

P0.03	Frequency source selection		Default	00
	Setting Range	Unit's digit (Frequency source)		
		0	Main frequency source X	
		1	X and Y operation (operation relationship determined by ten's digit)	
		2	Switchover between X and Y	
		3	Switchover between X and "X and Y operation"	
		4	Switchover between Y and "X and Y operation"	
		Ten's digit (X and Y operation)		
		0	X+Y	
		1	X-Y	
		2	Maximum	
		3	Minimum	

It is used to select the frequency setting channel. Through the main frequency source X and auxiliary frequency source Y compound to achieve a given frequency.

Unit's digit (Frequency source)

0: The main frequency X as the target frequency.

1: Advocate complementary operation result as the target frequency, advocate complementary relationship between operation meet the

function code "ten".

2:Main frequency source X and auxiliary frequency source Y switch when the multifunctional input terminal 18 (frequency switch) is invalid, the main frequency X as the target frequency. When the multifunctional input terminals function 18 (frequency source switch) is valid, auxiliary frequency Y as the target frequency.

3:The main switch frequency source X and advocate complementary operation results When the multi-function input terminals function 18 (frequency switch) is invalid, the main frequency X as the target frequency. When the multi-function input terminals function 18 (frequency switch) is valid, advocate complementary computing results as the target frequency.

4:Auxiliary switch frequency source Y and advocate complementary operation results When the multi-function input terminals function 18 (frequency switch) is invalid, auxiliary frequency Y as the target frequency. When the multi-function input terminals function 18 (frequency switch) is valid, advocate complementary computing results as the target frequency.

Ten: frequency source advocate complementary relationship between operation:

0:The main frequency of X and Y auxiliary frequency and frequency as the target.

1:Main frequency X minus Y auxiliary frequency difference as the target frequency.

2:MAX (the main frequency source X, the auxiliary frequency source Y) take the main frequency absolute value of the largest in the X and Y auxiliary frequency as the target frequency.

3:MIN (the main frequency source X, the auxiliary frequency source Y) take the main frequency the least absolute value of X and Y auxiliary frequency as the target frequency. In addition, when the frequency source selection of the advocate complementary computing, offset frequency, can be set by P0.21 offset frequency, superimposed on the advocate complementary operation results in a flexible response to various needs.

P0.04	Main frequency source X selection		Default	0
	Setting Range	0		Digital setting (P0.10 preset frequency, can modify the UP/DOWN, power lost don't memory)
1			Digital setting (P0.10 preset frequency, can modify the UP/DOWN, power lost memory)	
2			FIV	
3			FIC	
4			Reserved	
5			Pulse setting (X5)	
6			Multistage instruction	
7			PLC	
8			PID	
9			Communications given	

Choose inverter main input channel of a given frequency.

A total of 10 main a given frequency channel:

0: digital setting (power lost memory)

Set the initial value of frequency P010 (frequency preset) values. Can bring through a keyboard ▲ keys and ▼ keys (or multi-function input terminal of the UP and DOWN) to change the set frequency value of the frequency converter. Frequency converter after power off and power on again, set frequency values revert to P010 (digital frequency setting preset) values.

1: digital set (power lost memory)

Set the initial value of frequency P010 (frequency preset) values. Can bring by a keyboard ▲, ▼ keys (or multi-function input terminal of the UP and DOWN) to change the set frequency value of the frequency converter.

Frequency converter after power off and power on again, set frequency electric moment for the last set, through the keyboard bring ▲, ▼ keys or terminal correction by memories of UP and DOWN.

What need reminds is, P0.23 set for "digital frequency down memory choice", P0.23 is used to select the inverter when stop, frequency correction is memory was reset. P0.23 associated with downtime, not related to the power lost memory, applications to the note.

2: FIV

3: FIC

4: Reserved

Refers to the frequency by the analog inputs to determine. Z8000 panel provides two analog input terminal (FIV, FIC).

Among them, the FIV to 0V to 10V voltage input, FIC to 0V to 10V voltage input, can also be used for ma 4 ~ 20 mA current entered, jump line selection by the panel.

FIV, FIC of the Input voltage value, the corresponding relationship with the target frequency, users are free to choose. Z8000 provide 5 set of corresponding relation curve, three groups of curve for linear relationship (2 point correspondence), curve for the corresponding relation between 4 o'clock in the 2 groups of arbitrary curved line, the user can through the P4 group and C6 group function code setting.

P5.33 function code is used to set the FIV ~ the FIA three-way analog input, select which of the five groups of curve a respectively, and five specific corresponding relation curve, please refer to the description of P5, C6 group function code.

5: Pulse frequency (X5) given the given to a given by terminal pulse. Pulse signal given specifications: voltage range of 9 v~ 30 v and frequency range of 0 KHZ to 100 KHZ. Input pulse can only be given from multifunctional input terminals X5.

X5 terminal input pulse frequency and the corresponding set of relations, through the P5.28 ~ P5.31 setting, the corresponding relations between for 2 PM, the linear relation between the corresponding set of input pulses 100.0%, is refers to the relative maximum frequency P0.12 percentage.

6: Multistage instruction Choosing more paragraphs instruction operation mode, need through the digital quantity input X terminal state of different combination, corresponding to different frequency rate values. Z8000 can set more than four period of instruction terminals, four terminal 16 kinds of condition, can use the PC group code corresponding to the arbitrary function.

16 "instructions", "instruction" is relatively maximum frequency P0.12 percentage.

digital quantity input command terminal function, X terminal as more sections need to be done in group P5 corresponding Settings, please refer to the specific content P4 group of related function parameters.

#### 7: Simple PLC

Frequency source for simple PLC, frequency converter operation frequency source can be in 1 ~ 16 arbitrary frequency switching between operation instruction, holding time 1 ~ 16 frequency instructions, their respective deceleration time can also be user Settings, specific content reference PC set of instructions.

#### 8: PID

The selection process of PID control output as the operating

frequency. Commonly used in the scene of the closed loop control technology, such as constant pressure closed loop control, constant tension closed-loop control, etc. Application of PID as frequency source, you need to set up "PID" FA group related parameters.

9: Communication refers to the main frequency given source by the upper machine is given by way of communication. Z8000 support communication methods: modbus(standard),Profibus-DP(optional), CANlink(optional),CAN(optional).

		Auxiliary frequency source Y selection	Default	0
P0.05	Setting Range	0	digital setting (P0.10 preset frequency, can modify the UP/DOWN, power lost don't memory)	
		1	digital setting (P0.10 preset frequency, can modify the UP/DOWN, power lost memory)	
		2	FIV	
		3	FIC	
		4	Reserved	
		5	Pulse setting (X5)	
		6	Multistage instruction	
		7	PLC	
		8	PID	
		9	Communications given	

Auxiliary frequency source with the frequency for a given channel as an independent (i.e. frequency source selection of X to Y switch), its usage and the main frequency source with X, using the method can be reference P0.03 related instructions.

When auxiliary frequency source used as a superposition of a given (i.e. frequency source selection of X + Y, X to X + Y switch or Y to X + Y), the need to pay attention to:

1) When the auxiliary frequency source for digital timing, preset frequency (P0.10) doesn't work, the user through the keyboard bring ▲, ▼ button (or multi-function input terminal of UP and DOWN) on the frequency of adjustment, directly in the main on the basis of a given frequency adjustment.

2) When the auxiliary frequency source for analog input given (FIV, FIC) or to the input pulse timing, 100% of the input set corresponding auxiliary frequency source range, can be set by P0.06 and P0.07.

Source frequency pulse input to timing, similar to analog given. Tip: auxiliary frequency source selection and main frequency source X, Y can't set to the same channel, namely P0.04 and P0.05 don't set to the same value, otherwise easy to cause confusion.

P0.06	Auxiliary frequency source superposition Y range selection		Default	0
	Setting Range	0	Relative to the maximum frequency	
1		Relative to the main frequency source X		
P0.07	Auxiliary frequency source superposition Y range		Default	100%
	Setting Range		0%~150%	

When selecting frequency source for the superposition of "frequency" (P0.03 set to 1, 3, or 4), these two parameters used to determine the adjusting range of auxiliary frequency source.

P0.05 is used to determine the scope of the auxiliary frequency source of the object, the choice of relative to the maximum frequency, can also be relative to the rate of frequency source X, if choice is relative to the main frequency source, the scope of the secondary frequency source will change as the change of main frequency X.

P0.08	Acceleration time 1		Default	Model dependent
	Setting Range		0.00s~65000s	
P0.09	Deceleration time 1		Default	Model dependent
	Setting Range		0.00s~65000s	
P0.10	Frequency preset		Default	50.00Hz
	Setting Range		0.00 ~ maximum frequency (P0.12)	
P0.11	Rotation direction		Default	0
	Setting Range	0	Same direction	
		1	Reverse direction	

By changing the function code, can not change the purpose of the motor wiring and implement changes to, its effect is equivalent to adjust electric machine (U, V, W) any two lines for motor direction of rotation transformation.

Tip: after initialization parameter will restore the original state of the motor running direction. Good for system debugging after careful is forbidden to change the motor to occasion.

P0.12	Maximum frequency		Default	50.00Hz
	Setting Range		50.00Hz~320.00Hz	

In Z8000 analog input and pulse input (X5), period of instruction, etc., as a frequency source 100.0% of their relatively P0.10 calibration.

Z8000 maximum frequency output can reach 3200 Hz, instructions for both frequency resolution and the frequency range of input two refers to the standard, can choose frequency instruction through

**P0.22 decimal digits.**

When selecting P0.22 is 1, the frequency resolution of 0.1 Hz, the P0.10 set range 50.0 Hz ~ 3200.0 Hz;

When selecting P0.22 is 2, the frequency resolution of 0.01 Hz, the P0.10 set range 50.00Hz ~ 320.00 Hz;

P0.13	Upper limit frequency source		Default	0
	Setting Range	0	P0.12	
		1	FIV	
		2	FIC	
		3	Reserved	
		4	PULSE settings	
		5	communication settings	

Define the upper limit frequency source. Can come from upper limit frequency digital set (P0.12), also can from the analog input. When was capped with analog input frequency, analog input corresponding P0.12 set is 100%.

For example at the scene of the winding control using torque control mode, in order to avoid material break appear "ride" phenomenon, can use analog frequency cap, when the inverter running to the upper limit frequency value, the frequency converter in a maximum frequency operation.

P0.14	Upper limit frequency		Default	50.00Hz
	Setting Range	Frequency lower limit P0.16~Maximum frequency P0.12		
P0.15	Upper limit frequency offset		Default	0.00Hz
	Setting Range	0.00Hz~Maximum frequency P0.12		

When the upper limit set for analog or PULSE frequency, P0.13 as the set point offset, the offset frequency and P0.12 cap superposition frequency values, as the final limit frequency value.

P0.16	Frequency lower limit		Default	0.00Hz
	Setting Range	0.00Hz~Frequency upper limitP0.14		

Frequency instructions below P0.16 set the lower limit of frequency, frequency converter can stop and run at the lower frequency or a ship at zero speed line, what operation mode can be P8.14 (set frequency is lower than the lower limit frequency operation mode) Settings.

P0.17	Carrier frequency		Default	Model dependent
	Setting Range	1kHz~16.0kHz		

This function adjusting carrier frequency converter. By adjusting the carrier frequency can reduce electrical noise, to avoid the

resonance point of mechanical system, reduce the line of floor drain current and reducing interference caused by frequency converter.

When the carrier frequency is low, the output current of higher harmonic component increases, motor loss increase, the motor temperature increase. When the carrier frequency is higher, the motor loss is reduced, the motor temperature rise reduced, but the loss of the inverter increases, the temperature rise of the frequency converter increases, increased interference.

Adjusting the carrier frequency will affect the performance of the following:

Carrier frequency	low → high
The motor noise	large → small
The output current waveform	Bad → good
Temperature Rise in Electric Motors	High → low
The temperature rise of the frequency converter	Low → high
leak current	Small → large
Foreign raXated interference	Small → large

Different power converter, the carrier frequency of the factory Settings are different. Although the user can according to need to modify, but need to pay attention: if the carrier frequency set to a higher value than the factory, will lead to frequency converter radiator temperature increase, the user needs to use of frequency converter derating, otherwise the inverter is in danger of overheating alarm.

P0.18	Carrier frequency adjustment with temperature	Default	1
	Setting Range	0: No 1: Yes	

Carrier frequency with the temperature adjustment, is refers to the frequency converter is detected its radiator at high temperature, reduce the carrier frequency automatically, for lowering the temperature rise of the frequency converter. When the radiator at low temperature, carrier frequency returning to the set value. This feature can reduce inverter overheating reported to the police.

P0.19	Acceleration/Deceleration time unit	Default	1
	Setting Range	0	1s
		1	0.1s
	2	0.01s	

To meet the needs of all kinds of scene, Z8000 provides three kinds of deceleration time units, 1 seconds, 0.1 seconds, respectively, and

0.01 seconds.

Note: modify the function parameters, four groups of decimal digits, as suggested by the deceleration time will change, the deceleration time change, also pay special attention to in the course of application.

P0.21	Frequency offset of auxiliary frequency source for X and Y operation	Default	0.00Hz
	Setting Range	0.00Hz~maximum frequencyP0.12	

This function code is only valid at the time of frequency source selection of the advocate complementary computing.

When frequency source of the advocate complementary computing P0.21 as offset frequency, and advocate complementary computing results superposition frequency value, as the final frequency setting can be more flexible.

P0.22	Frequency reference	Default	2
	Setting Range	1	0.1Hz
		2	0.01Hz

All the parameters used to determine the resolution of the function code associated with the frequency.

When the frequency resolution of 0.1 Hz, Z8000 maximum output frequency can reach 3200 Hz, and the frequency resolution of 0.01 Hz, Z8000 maximum output frequency of 320.00 Hz.

Note: modify the function parameters, all related to the frequency parameters of decimal digits will change, the corresponding frequency values also produces change, pay special attention to in use.

P0.23	Retentive of digital setting frequency upon power failure	Default	0
	Setting Range	0	Not retentive
		1	Retentive

The function of frequency source for digital only effective when setting.

"No memory" refers to the frequency converter after downtime, digital frequency values revert to P0.10 (frequency preset )value, the keyboard bring ▲, ▼ button or terminal is UP and DOWN to correct the frequency is zero.

"Memory" refers to the frequency converter after downtime , digital set frequency keep set for the last moment of downtime, bring about keyboard ▲, ▼ button or terminal is UP and DOWN to correct the frequency of remain valid.

P0.24	Acceleration/Deceleration time base frequency		Default	0
	Setting Range	0	Maximum frequency (P0.12 )	
		1	Set frequency	
		2	100Hz	

Acceleration/Deceleration time, refers to the frequency from zero to P0.24 set frequency between the deceleration time, figure 6-1 schematic diagram for the deceleration time.

When the P0.24choice for 1, deceleration time is associated with a set frequency, if set frequency change frequently, the acceleration of the motor is variable, application note.

P0.25	Base frequency for UP/DOWN modification during running		Default	0
	Setting Range	0	Running frequency	
		1	Set frequency	

This parameter is only valid when frequency source for the digital setting.

Used to determine the bring ▲, ▼ button or terminal of the keyboard UP/DOWN action, adopt what way set frequency correction, the target frequency is based on the operating frequency, increase or decrease or based on a set frequency increase or decrease. Two set of distinction, evident when inverter in the deceleration process, namely, if the operation of the inverter frequency and setting frequency is not at the same time, the parameters of the different selection difference is very big.

P0.26	Binding command source to frequency source		Default	000
	Setting Range	Unit's digit	Binding operation panel command to frequency source	
		0	No binding	
		1	Frequency source by digital setting	
		2	FIV	
		3	FIC	
		4	Reserved	
		5	Pulse setting (X5)	
		6	Multi-reference	
		7	Simple PLC	
		8	PID	
		9	Communication setting	
		Ten's digit	Binding terminal command to frequency source(0-9, same as unit's digit)	
Hundred's digit	Binding communication command to frequency source (0-9, same as unit's digit)			

It is used to bind the three running command sources with the nine frequency sources, facilitating to implement synchronous switchover.

For details on the frequency sources, see the description of P0.03 (Main frequency source X selection). different running command sources can be bound to the same frequency source.

If a command source has a bound frequency source, the frequency source set in P003 to P007 no longer takes effect when the command source is effective.

P0.27	Communication expansion card type		Default	0
	Setting Range	0	Modbus communication card (standard)	
		1	Profibus-DP communication card	
		2	CAN communication card	

Z8000 provides three kinds of communication methods, the four kinds of communication methods need to be equipped with communication card can access, and four kinds of communication methods cannot be used at the same time.

This parameter is used to set the types, the matching of the communication card users communication card, this parameter must be set up correctly.

**Group P1:Start/Stop Control**

P1.00	Start mode		Default	0
	Setting Range	0	direct start	
		1	Rotational speed tracking restart	
		2	Pre-excited start (asynchronous motor)	

0: direct start

If the DC braking time is set to 0, the AC drive starts to run at the startup frequency. If the DC braking time is not 0, the AC drive performs DC braking first and then starts to run at the startup frequency. It is applicable to small-inertia load application where the motor is likely to rotate at startup.

1: Rotational speed tracking restart

The AC drive judges the rotational speed and direction of the motor first and then starts at the tracked frequency. Such smooth start has no impact on the rotating motor. It is applicable to the restart upon instantaneous power failure of large-inertia load. To ensure the performance of rotational speed tracking restart, set the motor parameters in group P2 correctly.

2: Pre-excited start (asynchronous motor)

It is valid only for asynchronous motor and used for building the magnetic

field before the motor runs. For pre-excited current and pre-excited time, see parameters of P1.05 and P1.06. If the pre-excited time is 0, the AC drive cancels pre-excitation and starts to run at startup frequency. If the pre-excited time is not 0, the AC drive pre-excites first before startup, improving the dynamic response of the motor.

P1.01	Rotational speed tracking mode		Default	0
	Setting Range	0	From frequency at stop	
		1	From zero speed	
		2	From maximum frequency	

To complete the rotational speed tracking process within the shortest time, select the proper mode in which the AC drive tracks the motor rotational speed.

0: From frequency at stop

It is the commonly selected mode.

1: From zero frequency

It is applicable to restart after a long time of power failure.

2: From the maximum frequency

It is applicable to the power-generating load.

P1.02	Rotational speed tracking speed	Default	20
	Setting Range	1~100	

In the rotational speed tracking restart mode, select the rotational speed tracking speed. The larger the value is, the faster the tracking is. However, too large value may cause unreliable Tracking.

P1.03	Startup frequency	Default	0.00Hz
	Setting Range	0.00Hz~10.00Hz	
P1.04	Startup frequency holding time	Default	0.0s
	Setting Range	0.0s~100.0s	

To ensure the motor torque at AC drive startup, set a proper startup frequency. In addition, to build excitation when the motor starts up, the startup frequency must be held for a certain Period.

The startup frequency (P1.03) is not restricted by the frequency lower limit. If the set target frequency is lower than the startup frequency, the AC drive will not start and stays in the standby state. During switchover between forward rotation and reverse rotation, the startup frequency holding time is disabled. The holding time is not included in the acceleration time but in the running time of simple PLC.

Example 1:

P0.04=0 The frequency source is digital setting.

P0.10=2.00Hz The digital setting frequency is 2.00 Hz.

P1.03=5.00Hz The startup frequency is 5.00 Hz.

P1.04=2.0s The startup frequency holding time is 2.0s.

In this example, the AC drive stays in the standby state and the output frequency is 0.00 Hz.

Example 2:

P0.04=0 The frequency source is digital setting.

P0.10=10.00Hz The digital setting frequency is 10.00 Hz.

P1.03=5.00Hz The startup frequency is 5.00 Hz.

P1.04=2.0s The startup frequency holding time is 2.0s.

In this example, the AC drive accelerates to 5.00 Hz, and then accelerates to the set frequency 10.00 Hz after 2s.

P1.05	Startup DC braking current/ Pre-excited current	Default	0%
	Setting Range	0%~100%	
P1.06	Startup DC braking time/ Pre-excited time	Default	0.0s
	Setting Range	0.0s~100.0s	

Startup DC braking is generally used during restart of the AC drive

after the rotating motor stops. Pre-excitation is used to make the AC drive build magnetic field for the asynchronous motor before startup to improve the responsiveness.

Startup DC braking is valid only for direct start. In this case, the AC drive performs DC braking at the set startup DC braking current. After the startup DC braking time, the AC drive starts to run. If the startup DC braking time is 0, the AC drive starts directly without DC braking. The larger the startup DC braking current is, the larger the braking force is.

If the startup mode is pre-excited start, the AC drive builds magnetic field based on the set pre-excited current. After the pre-excited time, the AC drive starts to run. If the pre-excited time is 0, the AC drive starts directly without pre-excitation. The startup DC braking current or pre-excited current is a percentage relative to the base Value.

If the rated motor current is less than or equal to 80% of the rated AC drive current, the base value is the rated motor current.

If the rated motor current is greater than 80% of the rated AC drive current, the base value is 80% of the rated AC drive current.

P1.07	Acceleration/ Deceleration mode		Default	0
	Setting Range	0	Linear acceleration/deceleration	
1		S-curve acceleration/deceleration A		
2		S-curve acceleration/deceleration B		

It is used to set the frequency change mode during the AC drive start and stop process.

0: Linear acceleration/deceleration

The output frequency increases or decreases in linear mode. The Z8000 provides four group of acceleration/deceleration time, which can be selected by using P5.00 to P5.08.

2: S-curve acceleration/deceleration B

In this curve, the rated motor frequency is always the inflexion point. This mode is fb usually used in applications where acceleration/deceleration is required at the speed higher than the rated frequency.

When the set frequency is higher than the rated frequency, the acceleration/deceleration time is:

$$t = \left( \frac{4}{9} * \left( \frac{f}{f_b} \right) + \frac{5}{9} \right) * T$$

In the formula, f is the set frequency, fb is the rated motor frequency and T is the acceleration time from 0 Hz to fb.

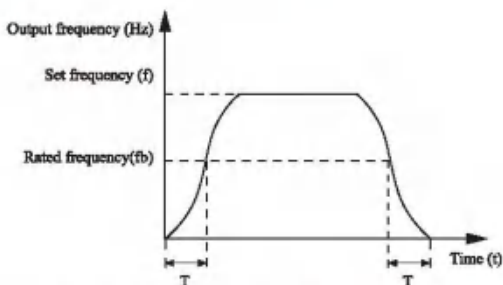

Figure 4-1 S-curve acceleration/deceleration B

P1.08	Time proportion of S-curve start segment	Default	30.0%
	Setting Range	0.0%~(100.0%-P1.09)	
P1.09	Time proportion of S-curve end segment	Default	30.0%
	Setting Range	0.0%~(100.0%-P1.08)	

These two parameters respectively define the time proportions of the start segment and the end segment of S-curve acceleration/deceleration. They must satisfy the requirement:

$$P1.08 + P1.09 \leq 100.0\%$$

In Figure 4-1,  $t_1$  is the time defined in P1.08, within which the slope of the output frequency change increases gradually.  $t_2$  is the time defined in P1.09, within which the slope of the output frequency change gradually decreases to 0. Within the time between  $t_1$  and  $t_2$ , the slope of the output frequency change remains unchanged, that is, linear acceleration/deceleration.

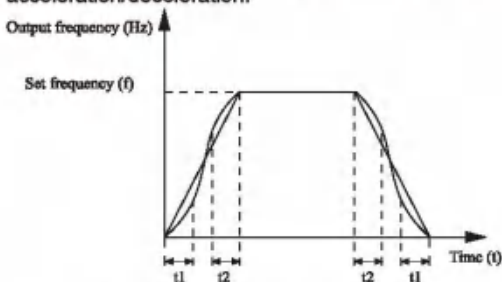

Figure 4-2 S-curve acceleration/deceleration A

P1.10	Stop mode		Default	0
	Setting Range	0	Decelerate to stop	
		1	Coast to stop	

**0: Decelerate to stop**

After the stop command is enabled, the AC drive decreases the output frequency according to the deceleration time and stops when the frequency decreases to zero.

**1: Coast to stop**

After the stop command is enabled, the AC drive immediately stops the output. The motor will coast to stop based on the mechanical inertia.

P1.11	Initial frequency of stop DC braking		Default	0.00Hz
	Setting Range	0.00 Hz~ maximum frequency		
P1.12	Waiting time of stop DC braking		Default	0.0s
	Setting Range	0.0s~100.0s		
P1.13	Stop DC braking current		Default	0%
	Setting Range	0%~100%		
P1.14	Stop DC braking time		Default	0.0s
	Setting Range	0.0s~100.0s		

**P1.11 (Initial frequency of stop DC braking)**

During the process of decelerating to stop, the AC drive starts DC braking when the running frequency is lower than the value set in P1.11.

**P1.12 (Waiting time of stop DC braking)**

When the running frequency decreases to the initial frequency of stop DC braking, the AC drive stops output for a certain period and then starts DC braking. This prevents faults such as over current caused due to DC braking at high speed.

**P1.13 (Stop DC braking current)**

This parameter specifies the output current at DC braking and is a percentage relative to the base value. If the rated motor current is less than or equal to 80% of the rated AC drive current, the base value is the rated motor current. If the rated motor current is greater than 80% of the rated AC drive current, the base value is 80% of the rated AC drive current.

**P1.14 (Stop DC braking time)**

This parameter specifies the holding time of DC braking. If it is set to 0, DC braking is cancelled. The stop DC braking process is shown in the following figure.

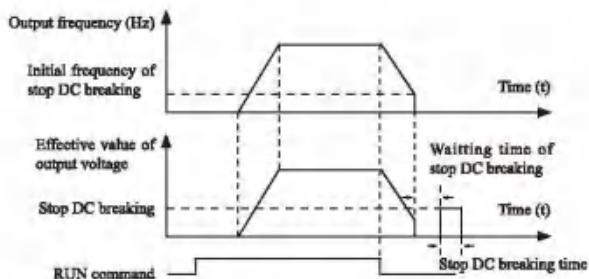

Figure 4-3 Stop DC braking process

P1.15	Brake use ratio	Default	100%
	Setting Range	0%~100%	

It is valid only for the AC drive with internal braking unit and used to adjust the duty ratio of the braking unit. The larger the value of this parameter is, the better the braking result will be. However, too larger value causes great fluctuation of the AC drive bus voltage during the braking process.

## Group P2: Motor Parameters

P2.00	Motor type selection	Default	0
	Setting Range	0: Common asynchronous motor 1: Variable frequency asynchronous motor 2: Permanent magnetic synchronous motor	
P2.01	Rated motor power	Default	Model dependent
	Setting Range	0.1kW~1000.0kW	
P2.02	Rated motor voltage	Default	Model dependent
	Setting Range	1V~2000V	
P2.03	Rated motor current	Default	Model dependent
	Setting Range	0.01A~655.35A (AC drive power≤55kW) 0.1A~6553.5A (AC drive power>55kW)	
P2.04	Rated motor frequency	Default	Model dependent
	Setting Range	0.01Hz~maximum frequency	
P2.05	Rated motor rotational speed	Default	Model dependent
	Setting Range	1rpm~65535rpm	

Set the parameters according to the motor nameplate no matter whether V/F control or vector control is adopted. To achieve better V/F or vector control performance, motor auto-tuning is required. The

motor auto-tuning accuracy depends on the correct setting of motor nameplate parameters.

P2.06	Stator resistance (asynchronous motor)	Default	Model dependent
	Setting Range	0.001Ω~30.000Ω	
P2.07	Rotor resistance (asynchronous motor)	Default	Model dependent
	Setting Range	0.001Ω~65.535Ω (AC drive power≤55kW) 0.0001Ω~6.5535Ω (AC drive power>55kW)	
P2.08	Leakage inductive reactance (asynchronous motor)	Default	Model dependent
	Setting Range	0.01mH~655.35mH (AC drive power≤55kW) 0.001mH~65.535mH (AC drive power>55kW)	
P2.09	Mutual inductive reactance (asynchronous motor)	Default	Model dependent
	Setting Range	0.1mH~6553.5mH (AC drive power≤55kW) 0.01mH~655.35mH (AC drive power>55kW)	
P2.10	No-load current (asynchronous motor)	Default	Model dependent
	Setting Range	0.01A~P2.03 (AC drive power≤55kW) 0.1A~P2.03 (AC drive power>55kW)	

The parameters in P2.06 to P2.10 are asynchronous motor parameters. These parameters are unavailable on the motor nameplate and are obtained by means of motor auto-tuning.

Only P2.06 to P2.08 can be obtained through static motor auto-tuning. Through complete motor auto-tuning, encoder phase sequence and current loop PI can be obtained besides the parameters in P2.06 to P2.10.

Each time "Rated motor power" (P2.01) or "Rated motor voltage" (P2.02) is changed, the AC drive automatically restores values of P2.06 to P2.10 to the parameter setting for the common standard Y series asynchronous motor.

If it is impossible to perform motor auto-tuning onsite, manually input the values of these parameters according to data provided by the motor manufacturer.

P2.16	Stator resistance (synchronous motor)	Default	Model dependent
	Setting Range	0.001Ω~65.535Ω (AC drive power≤55kW) 0.0001Ω~6.5535Ω (AC drive power>55kW)	

P2.17	Shaft D inductance (synchronous motor)	Default	Model dependent
	Setting Range	0.01mH~655.35mH (AC drive power≤55kW) 0.001mH~65.535mH (AC drive power>55kW)	
P2.18	Shaft Q inductance (synchronous motor)	Default	Model dependent
	Setting Range	0.01mH~655.35mH (AC drive power≤55kW) 0.001mH~65.535mH (AC drive power>55kW)	
P2.20	Back EMF (synchronous motor)	Default	Model dependent
	Setting Range	0.00V~8553.5V	

P2.16 to p2.20 are synchronous motor parameters. These parameters are unavailable on the nameplate of most synchronous motors and can be obtained by means of "Synchronous motor no-load auto-tuning". Through "Synchronous motor with-load auto-tuning", only the encoder phase sequence and installation angle can be obtained.

Each time "Rated motor power" (P2.01) or "Rated motor voltage" (P2.02) is changed, the AC drive automatically modifies the values of P2.16 to P2.20.

You can also directly set the parameters based on the data provided by the synchronous motor manufacturer.

P2.27	Encoder pulses per revolution	Default	1024
	Setting Range	1~65535	

This parameter is used to set the pulses per revolution (PPR) of ABZ or UVW incremental encoder. In CLVC mode, the motor cannot run properly if this parameter is set incorrectly.

P2.28	Encoder type	Default	2
	Setting Range	0	ABZ incremental encoder
		1	UVW incremental encoder
		2	Resolver
		3	SIN/COS encoder
4	Wire-saving UVW encoder		

Z8000 supports a variety of encoder type, different encoder needs matching PG card, please correct choose and buy when using the PG card. Among them, the synchronous motor optional choose the 5 kinds of either in the encoder, and generally only use asynchronous motor ABZ incremental encoder and rotating transformer.

After installed the PG card, according to the actual situation is set up correctly P2.28, otherwise inverter may not run properly.

Z8000 supports a variety of encoder type, different encoder needs

matching PG card, please correct choose and buy when using the PG card. Among them, the synchronous motor optional choose the 5 kinds of either in the encoder, and generally only use asynchronous motor ABZ incremental encoder and rotating transformer.

After installed the PG card, according to the actual situation is set up correctly P2.28, otherwise inverter may not run properly. The function code applies only to ABZ incremental encoder, the only effective when P2.28 = 0. Used to set the AB ABZ incremental encoder signal phase sequence.

The function code is effective to asynchronous motor and synchronous motor, the asynchronous motor complete tuning or no-load tuning of the synchronous motor, can be to get ABZ encoder AB phase sequence.

P2.30	ABZ incremental encoder AB phase sequence	Default	0
	Setting Range	0:Forward 1:Reverse	
P2.31	Encoder installation angle	Default	0.0°
	Setting Range	0.0°~359.9°	

This parameter is applicable only to synchronous motor. It is valid for ABZ incremental encoder, UVW incremental encoder, resolver and wire-saving UVW encoder, but invalid for SIN/COS encoder.

It can be obtained through synchronous motor no-load auto-tuning or with-load auto-tuning. After installation of the synchronous motor is complete, the value of this parameter must be obtained by motor auto-tuning. Otherwise, the motor cannot run properly.

P2.32	U, V, W phase sequence of UVW encoder	Default	0
	Setting Range	0	Forward
		1	Reverse
P2.33	UVW encoder angle offset	Default	0.0°
	Setting Range	0.0°~359.9°	

These two parameters are valid only when the UVW encoder is applied to a synchronous motor. They can be obtained by synchronous motor no-load auto-tuning or with-load auto-tuning. After installation of the synchronous motor is complete, the values of these two parameters must be obtained by motor auto-tuning. Otherwise, the motor cannot run properly.

P2.34	Number of pole pairs of resolver	Default	1
	Setting Range	1~65535	

If a resolver is applied, set the number of pole pairs properly.

P2.36	Encoder wire-break fault detection time	Default	0.0s
	Setting Range	0.0s: No action 0.1s~10.0s	

This parameter is used to set the time that a wire-break fault lasts. If it is set to 0.0s, the AC drive does not detect the encoder wire-break fault. If the duration of the encoder wire-break fault detected by the AC drive exceeds P2.36 the time set in this parameter, the AC drive reports Err20.

P2.37	Auto-tuning selection	Default	0
	Setting Range	0	No auto-tuning
		1	Asynchronous motor static auto-tuning
		2	Asynchronous motor complete auto-tuning
		11	Synchronous motor with-load auto-tuning
12	Synchronous motor no-load auto-tuning		

0: No auto-tuning

Auto-tuning is prohibited.

1: Asynchronous motor static auto-tuning

It is applicable to scenarios where complete auto-tuning cannot be performed because the asynchronous motor cannot be disconnected from the load.

Before performing static auto-tuning, properly set the motor type and motor nameplate parameters of P2.00 to P2.05 first. The AC drive will obtain parameters of P2.06 to P2.08 by static auto-tuning. Set this parameter to 1, and press RUN. Then, the AC drive starts static auto-tuning.

2: Asynchronous motor complete auto-tuning

To perform this type of auto-tuning, ensure that the motor is disconnected from the load. During the process of complete auto-tuning, the AC drive performs static auto-tuning first and then accelerates to 80% of the rated motor frequency within the acceleration time set in P008. The AC drive keeps running for a certain period and then decelerates to stop within deceleration time set in P009. Before performing complete auto-tuning, properly set the motor type, motor nameplate parameters of P2.00 to P2.05, "Encoder type" (P2.28) and "Encoder pulses per revolution" (P2.27) first.

The AC drive will obtain motor parameters of P2.06 to P2.10, "A/B phase sequence of ABZ incremental encoder" (P2.30) and vector control current loop PI parameters of P3.13 to P3.16 by complete auto-tuning. Set this parameter to 2, and press RUN. Then, the AC drive starts complete auto-tuning.

**11: Synchronous motor with-load auto-tuning**

It is applicable to scenarios where the synchronous motor cannot be disconnected from the load. During with-load auto-tuning, the motor rotates at the speed of 10 PRM. Before performing with-load auto-tuning, properly set the motor type and motor nameplate parameters of P2.00 to P2.05 first.

By with-load auto-tuning, the AC drive obtains the initial position angle of the synchronous motor, which is a necessary prerequisite of the motor's normal running. Before the first use of the synchronous motor after installation, motor auto-tuning must be performed.

Set this parameter to 11, and press RUN. Then, the AC drive starts with-load auto-tuning.

**12: Synchronous motor no-load auto-tuning**

If the synchronous motor can be disconnected from the load, no-load auto-tuning is recommended, which will achieve better running performance compared with with-load auto-tuning. During the process of no-load auto-tuning, the AC drive performs with-load auto-tuning first and then accelerates to P010 of the rated motor frequency within the acceleration time set in P008. The AC drive keeps running for a certain period and then decelerates to stop within the deceleration time set in P010. Before performing no-load auto-tuning, properly set the motor type, motor nameplate parameters of P2.00 to P2.05, "Encoder type" (P2.28) and "Encoder pulses per revolution" (P2.27) and "Number of pole pairs of resolver" (P2.34) first.

The AC drive will obtain motor parameters of P2.16 to P2.20, encoder related parameters of P2.30 to P2.33 and vector control current loop PI parameters of P3.13 to P3.16 by no-load auto-tuning. Set this parameter to 12, and press RUN. Then, the AC drive starts no-load auto-tuning.

Note: Motor auto-tuning can be performed only in operation panel mode.

**Group P3: Vector Control Parameters**

P3 group function code applies only to the vector control, control of V/F is invalid.

P3.00	Speed loop proportional gain 1	Default	30
	Setting Range	1~100	
P3.01	Speed loop integral time 1	Default	0.50s
	Setting Range	0.01s~10.00s	
P3.02	Switchover frequency 1	Default	5.00Hz
	Setting Range	0.00~P3.05	

P3.03	Speed loop proportional gain 2	Default	20
	Setting Range	1~100	
P3.04	Speed loop integral time 2	Default	1.00s
	Setting Range	0.01s~10.00s	
P3.05	Switchover frequency 2	Default	10.00Hz
	Setting Range	P3.02~maximum output frequency	

Speed loop PI parameters vary with running frequencies of the AC drive.

If the running frequency is less than or equal to "Switchover frequency 1" (P3.02), the speed loop PI parameters are P3.00 and P3.01.

If the running frequency is equal to or greater than "Switchover frequency 2" (P3.05), the speed loop PI parameters are P3.03 and P3.04.

If the running frequency is between P3.02 and P3.05, the speed loop PI parameters are obtained from the linear switchover between the two groups of PI parameters, as shown in Figure 4-3.

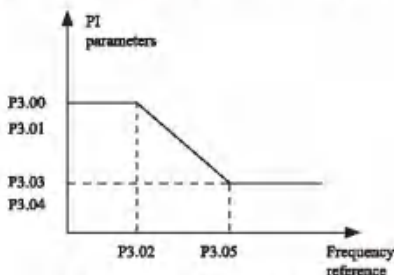

Figure 4-4 Relationship between running frequencies and PI parameters

The speed dynamic response characteristics in vector control can be adjusted by setting the proportional gain and integral time of the speed regulator.

To achieve a faster system response, increase the proportional gain and reduce the integral time. Be aware that this may lead to system oscillation.

The recommended adjustment method is as follows:

If the factory setting cannot meet the requirements, make proper adjustment. Increase the proportional gain first to ensure that the system does not oscillate, and then reduce the integral time to ensure that the system has quick response and small overshoot.

Note: Improper PI parameter setting may cause too large speed

overshoot, and overvoltage fault may even occur when the overshoot drops.

P3.06	Vector control slip gain	Default	100%
	Setting Range	50%~200%	

For SFVC, it is used to adjust speed stability accuracy of the motor. When the motor with load runs at a very low speed, increase the value of this parameter; when the motor with load runs at a very large speed, decrease the value of this parameter.

For CLVC, it is used to adjust the output current of the AC drive with same load.

P3.07	Time constant of speed loop filter	Default	0.000s
	Setting Range	0.000s~0.100s	

In the vector control mode, the output of the speed loop regulator is torque current reference. This parameter is used to filter the torque references. It need not be adjusted generally and can be increased in the case of large speed fluctuation. In the case of motor oscillation, decrease the value of this parameter properly. If the value of this parameter is small, the output torque of the AC drive may fluctuate greatly, but the response is quick.

P3.08	Vector control over-excitation gain	Default	64
	Setting Range	0~200	

During deceleration of the AC drive, over-excitation control can restrain rise of the bus voltage to avoid the overvoltage fault. The larger the over-excitation gain is, the better the restraining effect is. Increase the over-excitation gain if the AC drive is liable to overvoltage error during deceleration. Too large over-excitation gain, however, may lead to an increase in output current. Therefore, set this parameter to a proper value in actual applications.

Set the over-excitation gain to 0 in applications of small inertia (the bus voltage will not rise during deceleration) or where there is a braking resistor.

P3.09	Torque upper limit source in speed control mode	Default	0
	Setting Range	0	P3.10
		1	FIV
		2	FIC
		3	reserved
		4	Pulse setting
5	Communication setting		

P3.10	digital setting of torque upper limit in speed control mode	Default	150.0%
	Setting Range	0.0%~200.0%	

In the speed control mode, the maximum output torque of the AC drive is restricted by P3.09. If the torque upper limit is analog, pulse or communication setting, 100% of the setting corresponds to the value of P3.10, and 100% of the value of P3.10 corresponds to the AC drive rated torque.

P3.13	Excitation adjustment proportional gain	Default	2000
	Setting Range	0~60000	
P3.14	Excitation adjustment integral gain	Default	1300
	Setting Range	0~60000	
P3.15	Torque adjustment proportional gain	Default	2000
	Setting Range	0~60000	
P3.16	Torque adjustment integral gain	Default	1300
	Setting Range	0~60000	
P3.17	Speed loop integra property1	Default	0
	Bits: Integral Separation	0	0: Invalid
		1	1: valid

These are current loop PI parameters for vector control. These parameters are automatically obtained through "Asynchronous motor complete auto-tuning" or "Synchronous motor no-load auto-tuning", and need not be modified.

The dimension of the current loop integral regulator is integral gain rather than integral time.

Note that too large current loop PI gain may lead to oscillation of the entire control loop. Therefore, when current oscillation or torque fluctuation is great, manually decrease the proportional gain or integral gain here.

These parameters are used to set field weakening control for the synchronous motor.

P3.18	Field weakening mode of synchronous motor	Default	1
	Setting Range	0	No field weakening
		1	direct calculation
		2	Automatic adjustment

P3.19	Field weakening depth of synchronous motor	Default	100%
	Setting Range	50%~500%	
P3.20	Maximum field weakening	Default	50%
	Setting Range	1%~300%	
P3.21	Field weakening automatic adjustment gain	Default	100%
	Setting Range	10%~500%	
P3.22	Field weakening integral	Default	2
	Setting Range	2~10	

If P3.18 is set to 0, field weakening control on the synchronous motor is disabled. In this case, the maximum rotational speed is related to the AC drive bus voltage. If the motor's maximum rotational speed cannot meet the requirements, enable the field weakening function to increase the speed.

The Z8000 provides two field weakening modes: direct calculation and automatic adjustment. In direct calculation mode, directly calculate the demagnetized current and manually adjust the demagnetized current by means of P3.19. The smaller the demagnetized current is, the smaller the total output current is. However, the desired field weakening effect may not be achieved. In automatic adjustment mode, the best demagnetized current is selected automatically. This may influence the system dynamic performance or cause instability. The adjustment speed of the field weakening current can be changed by modifying the values of P3.21 and P3.22. A very quick adjustment may cause instability. Therefore, generally do not modify them manually.

#### Group P4: V/F Control Parameters

The V/F control mode is applicable to low load applications (fan or pump) or applications where one AC drive operates multiple motors or there is a large difference between the AC drive power and the motor power.

P4.00	V/F curve setting		Default	0
	Setting Range	0		
1				Multi-point V/F
2				Square V/F
3				1.2-power V/F
4				1.4-power V/F
6				1.6-power V/F
8				1.8-power V/F
9				Reserved
10				V/F complete separation
11				V/F half separation

**0: Linear V/F**

It is applicable to common constant torque load.

**1: Multi-point V/F**

It is applicable to special load such as dehydrator and centrifuge. Any such V/F curve can be obtained by setting parameters of P4.03 to P4.08.

**2: Square V/F**

It is applicable to centrifugal loads such as fan and pump.

**3 to 8: V/F curve between linear V/F and square V/F**
**10: V/F complete separation**

In this mode, the output frequency and output voltage of the AC drive are independent. The output frequency is determined by the frequency source, and the output voltage is determined by "Voltage source for V/F separation" (P4.13).

It is applicable to induction heating, inverse power supply and torque motor control.

**11: V/F half separation**

In this mode, V and F are proportional and the proportional relationship can be set in P4.13. The relationship between V and F are also related to the rated motor voltage and rated motor frequency in Group P2.

Assume that the voltage source input is X (0 to 100%), the relationship between V and F is:  $V/F = 2 \times X \times (\text{Rated motor voltage})/(\text{Rated motor frequency})$

P4.01	Torque boost		Default	Model dependent
	Setting Range	0.0%~30%		
P4.02	Cut-off frequency of torque boost		Default	50.00Hz
	Setting Range	0.00Hz~maximum output frequency		

To compensate the low frequency torque characteristics of V/F control, you can boost the output voltage of the AC drive at low

frequency by modifying P4.01. If the torque boost is set to too large, the motor may overheat, and the AC drive may suffer over current. If the load is large and the motor startup torque is insufficient, increase the value of P4.01. If the load is small, decrease the value of P4.01. If it is set to 0.0, the AC drive performs automatic torque boost. In this case, the AC drive automatically calculates the torque boost value based on motor parameters including the stator resistance. P4.02 specifies the frequency under which torque boost is valid. Torque boost becomes invalid when this frequency is exceeded, as shown in the following figure.

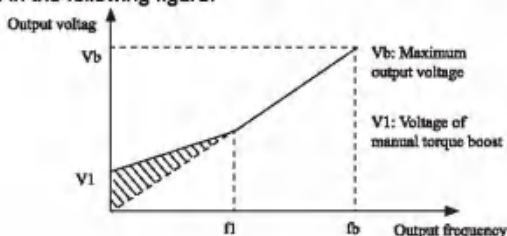

f1: Cutoff frequency of manual torque boost f2: Rated running frequency

Figure 4-5 Manual torque boost

P4.03	Multi-point V/F frequency 1 (F1)	Default	0.00Hz
	Setting Range	0.00Hz~P4.05	
P4.04	Multi-point V/F voltage 1 (V1)	Default	0.0%
	Setting Range	0.0%~100.0%	
P4.05	Multi-point V/F frequency 2 (F2)	Default	0.00Hz
	Setting Range	P4.03~P4.07	
P4.06	Multi-point V/F voltage 2 (V2)	Default	0.0%
	Setting Range	0.0%~100.0%	
P4.07	Multi-point V/F frequency 3 (F3)	Default	0.00Hz
	Setting Range	P4.05~rated motor frequency (P2.04)	
P4.08	Multi-point V/F voltage 3 (V3)	Default	0.0%
	Setting Range	0.0%~100.0%	

These six parameters are used to define the multi-point V/F curve. The multi-point V/F curve is set based on the motor's load characteristic. The relationship between voltages and frequencies is:  $V1 < V2 < V3$ ,  $F1 < F2 < F3$ . At low frequency, higher voltage may cause overheat or even burnt out of the motor and overcurrent stall or overcurrent protection of the AC drive.

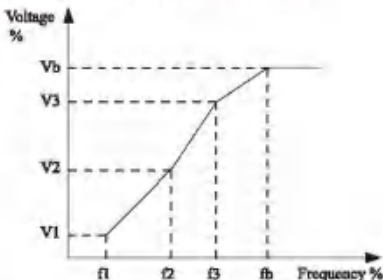

V1-V3: 1 st 2nd and 3rd voltage F1-F3: 1 st 2nd and 3rd frequency percentages of multi-point V/F percentages of multi-point V/F  
 Vb: Rated motor voltage Fb: Rated motor running frequency  
 Figure 4-6 Setting of multi-point V/F curve

P4.09	V/F slip compensation gain	Default	0.0%
	Setting Range	0%~200.0%	

This parameter is valid only for the asynchronous motor. It can compensate the rotational speed slip of the asynchronous motor when the load of the motor increases, stabilizing the motor speed in case of load change. If this parameter is set to 100%, it indicates that the compensation when the motor bears rated load is the rated motor slip. The rated motor slip is automatically obtained by the AC drive through calculation based on the rated motor frequency and rated motor rotational speed in group P2. Generally, if the motor rotational speed is different from the target speed, slightly adjust this Parameter.

P4.10	V/F over-excitation gain	Default	64
	Setting Range	0~200	

During deceleration of the AC drive, over-excitation can restrain rise of the bus voltage, preventing the overvoltage fault. The larger the over-excitation is, the better the restraining result is. Increase the over-excitation gain if the AC drive is liable to overvoltage error during deceleration. However, too large over-excitation gain may lead to an increase in the output current. Set

P4.09 to a proper value in actual applications.

Set the over-excitation gain to 0 in the applications where the inertia is small and the bus voltage will not rise during motor deceleration or where there is a braking resistor.

P4.11	V/F oscillation suppression gain	Default	Model dependent
	Setting Range	0~100	

Set this parameter to a value as small as possible in the prerequisite of efficient oscillation suppression to avoid influence on V/F control. Set this parameter to 0 if the motor has no oscillation. Increase the value properly only when the motor has obvious oscillation. The larger the value is, the better the oscillation suppression result will be.

When the oscillation suppression function is enabled, the rated motor current and no-load current must be correct. Otherwise, the V/F oscillation suppression effect will not be satisfactory.

P4.13	Voltage source for V/F separation	Default	0
	Setting Range	0	digital setting (P4.14)
		1	FIV
		2	FIC
		3	Reserved
		4	Pulse setting (X5)
		5	Multi-reference
		6	Simple PLC
		7	PID
		8	Communication setting
		100.0% corresponds to the rated motor voltage.	
P4.14	Voltage digital setting for V/F separation	Default	0V
	Setting Range	0V~rated motor voltage	

V/F separation is generally applicable to scenarios such as induction heating, inverse power supply and motor torque control.

If V/F separated control is enabled, the output voltage can be set in P4.14 or by means of analog, multi-reference, simple PLC, PID or communication. If you set the output voltage by means of non-digital setting, 100% of the setting corresponds to the rated motor voltage. If a negative percentage is set, its absolute value is used as the effective value.

0: digital setting (P4.14)

The output voltage is set directly in P4.14.

1: FIV; 2:FIC; 3: Reserved.

#### 4: Pulse setting (X5)

The output voltage is set by pulses of the terminal X5.

Pulse setting specification: voltage range 9–30 V, frequency range 0–100 kHz

#### 5: Multi-reference

If the voltage source is multi-reference, parameters in group P4 and PC must be set to determine the corresponding relationship between setting signal and setting voltage.

100.0% of the multi-reference setting in group FC corresponds to the rated motor voltage.

#### 6: Simple PLC

If the voltage source is simple PLC mode, parameters in group FC must be set to determine the setting output voltage.

#### 7: PID

The output voltage is generated based on PID closed loop. For details, see the description of PID in group PA.

#### 8: Communication setting

The output voltage is set by the host computer by means of communication.

The voltage source for V/F separation is set in the same way as the frequency source. 100.0% of the setting in each mode corresponds to the rated motor voltage. If the corresponding value is negative, its absolute value is used.

P4.15	Voltage rise time of V/F separation	Default	0.0s
	Setting Range	0.0s~1000.0s	

P4.15 indicates the time required for the output voltage to rise from 0 V to the rated motor voltage shown as t1 in the following figure.

P4.16 indicates the time required for the output voltage to decline from the rated motor voltage to 0 V, shown as t2 in the following figure.

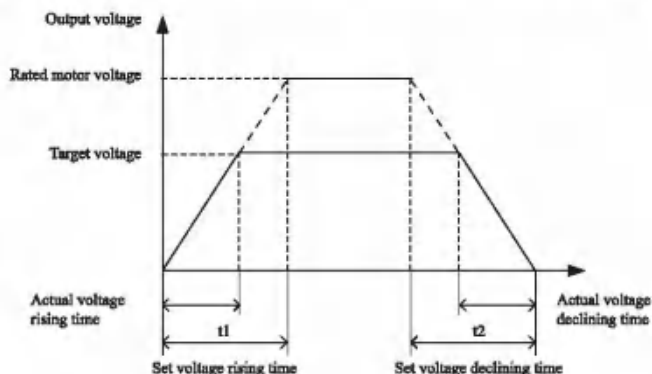

Figure 4-7 Voltage of V/F separation

### Group P5: Input Terminals

Z8000 series inverter with 8 multi-function digital inputs (X5 can be used as a high-speed pulse input terminal), two analog input terminals.

P5.00	X1 function selection	Default	1 (Forward RUN)
P5.01	X2 function selection	Default	2 (Reverse RUN)
P5.02	X3 function selection	Default	9 (Fault reset)
P5.03	X4 function selection	Default	12 (Multi-reference terminal 1)
P5.04	X5 function selection	Default	13 (Multi-reference terminal 2)
P5.05	X6 function selection	Default	0
P5.06	X7 function selection	Default	0
P5.07	X8 function selection	Default	0
P5.08	X9 function selection		Reserved
P5.09	X10 function selection		Reserved

The following table lists the functions available for the X terminals.

Table 4-1 Functions of X terminals

Value	Function	Description
0	No function	Set 0 for reserved terminals to avoid malfunction.
1	Forward RUN (FWD)	The terminal is used to control forward or reverse RUN of the AC drive.
2	Reverse RUN (REV)	
3	Three-line control	The terminal determines three-line control of the AC drive. For details, see the description of P5.11.

Value	Function	Description
4	Forward JOG (FJOG)	FJOG indicates forward JOG running, while RJOG indicates reverse JOG running. The JOG frequency, acceleration time and deceleration time are described respectively in P8.00, P8.01 and P8.02.
5	Reverse JOG (RJOG)	
6	Terminal UP	If the frequency is determined by external terminals, the terminals with the two functions are used as increment and decrement commands for frequency modification. When the frequency source is digital setting, they are used to adjust the frequency.
7	Terminal DOWN	
8	Coast to stop	The AC drive blocks its output, the motor coasts to rest and is not controlled by the AC drive. It is the same as coast to stop described in P1.10.
9	Fault reset (RESET)	The terminal is used for fault reset function, the same as the function of RESET key on the operation panel. Remote fault reset is implemented by this function.
10	RUN pause	The AC drive decelerates to stop, but the running parameters are all memorized, such as PLC, swing frequency and PID parameters. After this function is disabled, the AC drive resumes its status before stop.
11	Normally open (NO) input of external fault	If this terminal becomes ON, the AC drive reports E15 and performs the fault protection action. For more details, see the description of P9.47.
12	Multi-reference terminal 1	The setting of 16 speeds or 16 other references can be implemented through combinations of 16 states of these four terminals.
13	Multi-reference terminal 2	
14	Multi-reference terminal 3	
15	Multi-reference terminal 4	
16	Terminal 1 for acceleration/ deceleration time selection	Totally four groups of acceleration/ deceleration time can be selected through combinations of two states of these two terminals.
17	Terminal 2 for acceleration/ deceleration time selection	
18	Frequency source switchover	The terminal is used to perform switchover between two frequency sources according to the setting in P007.

Value	Function	Description
19	UP and DOWN setting clear (terminal, operation panel)	If the frequency source is digital setting, the terminal is used to clear the modification by using the UP/DOWN function or the increment/decrement key on the operation panel, returning the set frequency to the value of P010.
20	Command source switchover terminal	If the command source is set to terminal control (P002 = 1), this terminal is used to perform switchover between terminal control and operation panel control. If the command source is set to communication control (P002 = 2), this terminal is used to perform switchover between communication control and operation panel control.
21	Acceleration/Deceleration prohibited	It enables the AC drive to maintain the current frequency output without being affected by external signals (except the STOP command).
22	PID pause	PID is invalid temporarily. The AC drive maintains the current frequency output without supporting PID adjustment of frequency source.
23	PLC status reset	The terminal is used to restore the original status of PLC control for the AC drive when PLC control is started again after a pause.
24	Swing pause	The AC drive outputs the central frequency, and the swing frequency function pauses.
25	Counter input	This terminal is used to count pulses.
26	Counter reset	This terminal is used to clear the counter status.
27	Length count input	This terminal is used to count the length.
28	Length reset	This terminal is used to clear the length.
29	Torque control prohibited	The AC drive is prohibited from torque control and enters the speed control mode.
30	Pulse input (enabled only for X5)	X5 is used for pulse input.
31	Reserved	Reserved
32	Immediate DC braking	After this terminal becomes ON, the AC drive directly switches over to the DC braking state.
33	Normally closed (NC) input of external fault	After this terminal becomes ON, the AC drive reports E15 and stops.
34	Frequency modification forbidden	After this terminal becomes ON, the AC drive does not respond to any frequency modification.

Value	Function	Description
35	Reverse PID action direction	After this terminal becomes ON, the PID action direction is reversed to the direction set in PA.03.
36	External STOP terminal 1	In operation panel mode, this terminal can be used to stop the AC drive, equivalent to the function of the STOP key on the operation panel.
37	Command source switchover terminal 2	It is used to perform switchover between terminal control and communication control. If the command source is terminal control, the system will switch over to communication control after this terminal becomes ON.
38	PID integral pause	After this terminal becomes ON, the integral adjustment function pauses. However, the proportional and differentiation adjustment functions are still valid.
39	Switchover between main frequency source X and preset frequency	After this terminal becomes ON, the frequency source X is replaced by the preset frequency set in P010.
40	Switchover between auxiliary frequency source Y and preset frequency	After this terminal is enabled, the frequency source Y is replaced by the preset frequency set in P010.
41	Motor selection terminal 1	Reserved
42	Motor selection terminal 2	
43	PID parameter switchover	If the PID parameters switchover performed by means of X terminal (PA.18 = 1), the PID parameters are PA.05 to PA.07 when the terminal becomes OFF; the PID parameters are PA.15 to PA.17 when this terminal becomes ON.
44	User-defined fault 1	Reserved
45	User-defined fault 2	
46	Speed control/ Torque control switchover	This terminal enables the AC drive to switch over between speed control and torque control. When this terminal becomes OFF, the AC drive runs in the mode set in C0.00. When this terminal becomes ON, the AC drive switches over to the other control mode.

Value	Function	Description
47	Emergency stop	When this terminal becomes ON, the AC drive stops within the shortest time. During the stop process, the current remains at the set current upper limit. This function is used to satisfy the requirement of stopping the AC drive in emergency state.
48	External STOP terminal 2	In any control mode (operation panel, terminal or communication), it can be used to make the AC drive decelerate to stop. In this case, the deceleration time is deceleration time 4.
49	Deceleration DC braking	When this terminal becomes ON, the AC drive decelerates to the initial frequency of stop DC braking and then switches over to DC braking state.
50	Clear the current running time	When this terminal becomes ON, the AC drive's current running time is cleared. This function must be supported by P8.42 and P8.53.

The four multi-reference terminals have 16 state combinations, corresponding to 16 reference values, as listed in the following table.

Table 4-2 State combinations of the four multi-reference terminals

K4	K3	K2	K1	Reference Setting	CorresponXng Parameter
OFF	OFF	OFF	OFF	Reference 0	PC.00
OFF	OFF	OFF	ON	Reference 1	PC.01
OFF	OFF	ON	OFF	Reference 2	PC.02
OFF	OFF	ON	ON	Reference 3	PC.03
OFF	ON	OFF	OFF	Reference 4	PC.04
OFF	ON	OFF	ON	Reference 5	PC.05
OFF	ON	ON	OFF	Reference 6	PC.06
OFF	ON	ON	ON	Reference 7	PC.07
ON	OFF	OFF	OFF	Reference 8	PC.08
ON	OFF	OFF	ON	Reference 9	PC.09
ON	OFF	ON	OFF	Reference 10	PC.10
ON	OFF	ON	ON	Reference 11	PC.11
ON	ON	OFF	OFF	Reference 12	PC.12
ON	ON	OFF	ON	Reference 13	PC.13
ON	ON	ON	OFF	Reference 14	PC.14
ON	ON	ON	ON	Reference 15	PC.15

If the frequency source is multi-reference, the value 100% of PC.00 to PC.15 corresponds to the value of P0.12 (Maximum frequency). Besides the multi-speed function, the multi-reference can be

also used as the PID setting source or the voltage source for V/F separation, satisfying the requirement on switchover of different setting values.

Two terminals for acceleration/deceleration time selection have four state combinations, as listed in the following table.

Table 4-3 State combinations of two terminals for acceleration/deceleration time selection

Terminal2	Terminal1	Acceleration/Deceleration Time Selection	Corresponding Parameters
OFF	OFF	Acceleration/Deceleration time 1	P0.17, P0.18
OFF	ON	Acceleration/Deceleration time 2	P8.03, P8.04
ON	OFF	Acceleration/Deceleration time 3	P8.05, P8.06
ON	ON	Acceleration/Deceleration time 4	P8.07, P8.08

P5.10	X filter time	Default	0.010s
	Setting Range	0.000s~1.000s	

It is used to set the software filter time of X terminal status. If X terminals are liable to interference and may cause malfunction, increase the value of this parameter to enhance the anti-interference capability. However, increase of X filter time will reduce the response of X terminals.

P5.11	Terminal command mode	Default	0	
	Setting Range	0	Two-line mode 1	
		1	Two-line mode 2	
		2	Three-line mode 1	
		3	Three-line mode 2	

This parameter defines the external terminal, control frequency converter running four different ways.

0:Two-line mode 1: this pattern is most commonly used two line mode. Determined by terminal Xx, Xy, positive and reverse operation of the motor.

The parameters are set as below:

Terminal	Set value	Function Description
Xx	1	Forward RUN (FWD)
Xy	2	Reverse RUN (REV)

Among them, Xx, Xy is X1 ~ X10 multi-function input terminals, level effectively.

Figure 4-8 Setting of two-line mode 1

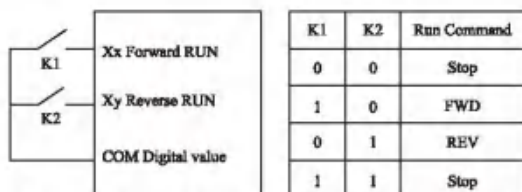

1: Two-line mode 2: use this pattern when Xx terminal functions for operation can make terminal, and Xy terminal function determined to run.

The parameters are set as below:

Terminal	Set value	Function Description
Xx	1	Forward RUN (FWD)
Xy	2	Reverse RUN (REV)

Among them, Xx, Xy is X1 ~ X10 multi-function input terminals, level effectively.

Figure 4-9 Setting of two-line mode 2

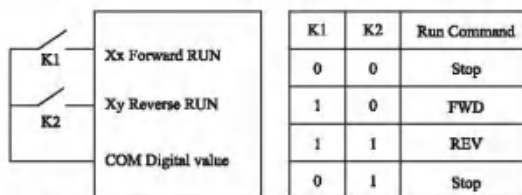

## 2: Three-line mode 1

In this mode, Xn is RUN enabled terminal, and the direction is decided by Xx and Xy.

The parameters are set as below:

Terminal	Set value	Function Description
Xx	1	Forward RUN (FWD)
Xy	2	Reverse RUN (REV)
Xn	3	Three-line control

Must be closed when the need to run, Xn, terminal by Xx or pulse rising along the x, y of the forward and reverse control system of the machine. When need to stop, must be done by disconnect Xn terminal signal. Among them, the Xx, Xy, Xn as X1 ~ X10 multi-function input terminals, Xx, Xy for pulse effectively, Xn level

effectively.

Figure 4-10-1 Setting of three-line mode 1

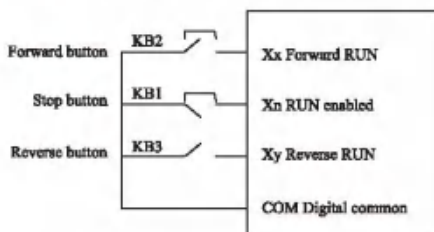

### 3: Three-line mode 2

In this mode, Xn is RUN enabled terminal. The RUN command is given by Xx and the direction is decided by Xy.

The parameters are set as below:

Terminal	Set value	Function Description
Xx	1	Forward RUN (FWD)
Xy	2	Reverse RUN (REV)
Xn	3	Three-line control

Must be closed when the need to run, Xn terminals, produced by Xx pulse rising along the motor running signal, the state of the Xy produce motor signals. When need to stop, must be done by disconnect Xn terminal signal. Among them, the Xx, x, y, Xn as X1 ~ X10 multi-function input terminals, Xx for pulse effectively, Xy, Xn level effectively.



Figure 4-10-2 Setting of three-line mode 2

P5.12	Terminal UP/DOWN rate	Default	1.00Hz/s
	Setting Range	0.01Hz/s~65.535Hz/s	

It is used to adjust the rate of change of frequency when the frequency is adjusted by means of terminal UP/DOWN.

If P0.22 (Frequency reference resolution) is 2, the setting range is 0.001–65.535 Hz/s.

If P0.22 (Frequency reference resolution) is 1, the setting range is 0.01–655.35 Hz/s.

P5.13	FI curve 1 minimum input	Default	0.00V
	Setting Range	0.00V~P5.15	
P5.14	Corresponding setting of FI curve 1 minimum input	Default	0.0%
	Setting Range	-100.00%~100.0%	
P5.15	FI curve 1 maximum input	Default	10V
	Setting Range	P5.13~10.00V	
P5.16	Corresponding setting of FI curve 1 maximum input	Default	100%
	Setting Range	-100.00%~100.0%	
P5.17	FI curve 1 filter time	Default	0.10s
	Setting Range	0.00s~10.00s	

These parameters are used to define the relationship between the analog input voltage and the corresponding setting. When the analog input voltage exceeds the maximum value (P5.15), the maximum value is used. When the analog input voltage is less than the minimum value (P5.13), the value set in P5.34 (Setting for FI less than minimum input) is used.

When the analog input is current input, 1 mA current corresponds to 0.5 V voltage.

P5.17 (FI curve 1 filter time) is used to set the software filter time of FI. If the analog input is liable to interference, increase the value of this parameter to stabilize the detected analog input.

However, increase of the FI curve 1 filter time will slow the response of analog detection. Set this parameter properly based on actual conditions.

In different applications, 100% of analog input corresponds to different nominal values. For details, refer to the description of different applications.

Two typical setting examples are shown in the following figure.

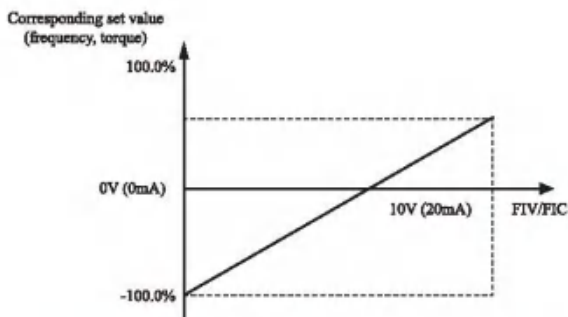
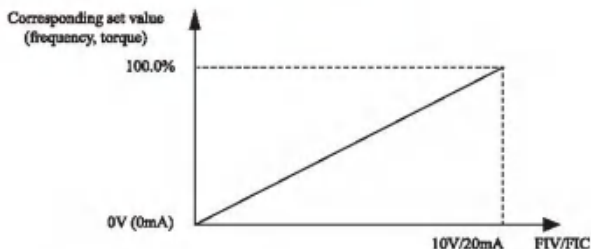

Figure 4-11 Corresponding relationship between analog input and set values

P5.18	FI curve 2 minimum input	Default	0.00V
	Setting Range	0.00V~P5.20	
P5.19	Corresponding setting of FI curve 2 minimum input	Default	0.0%
	Setting Range	-100.00%~100.0%	
P5.20	FI curve 2 maximum input	Default	10.00V
	Setting Range	P5.18~10.00V	
P5.21	Corresponding setting of FI curve 2 maximum input	Default	100.0%
	Setting Range	-100.00%~100.0%	
P5.22	FI curve 2 filter time	Default	0.10s
	Setting Range	0.00s~10.00s	
P5.23	FI curve 3 minimum input	Default	0.00V
	Setting Range	0.00s~P5.25	

P5.24	Corresponding setting of FI curve 3 minimum input	Default	0.0%
	Setting Range	-100.00%~100.0%	
P5.25	FI curve 3 maximum input	Default	10.00V
	Setting Range	P5.23~10.00V	
P5.26	Corresponding setting of FI curve 3 maximum input	Default	100.0%
	Setting Range	-100.00%~100.0%	
P5.27	FI curve 3 filter time	Default	0.10s
	Setting Range	0.00s~10.00s	

The method of setting FI curve 2 and FI curve 3 functions is similar to that of setting FI curve 1 function

P5.28	PULSE minimum input	Default	0.00kHz
	Setting Range	0.00kHz~P5.30	
P5.29	Corresponding setting of pulse minimum input	Default	0.0%
	Setting Range	-100.00%~100.0%	
P5.30	PULSE maximum input	Default	50.00kHz
	Setting Range	P5.28~100.00kHz	
P5.31	Corresponding setting of pulse maximum input	Default	100.0%
	Setting Range	-100.00%~100.0%	
P5.32	PULSE filter time	Default	0.10s
	Setting Range	0.00s~10.00s	

These parameters are used to set the relationship between X5 pulse input and corresponding settings. The pulses can only be input by X5. The method of setting this function is similar to that of setting FI curve 1 function.

P5.33	FI curve selection		Default	321
	Setting Range	Unit's digit	FIV curve selection	
		1	Curve 1 (2 points, see P5.13~P5.16)	
		2	Curve 2 (2 points, see P5.18~P5.21)	
		3	Curve 3 (2 points, see P5.23~P5.26)	
		4	Curve 4 (4 points, see C6.00~C6.07)	
		5	Curve 5 (4 points, see C6.08~C6.15)	
Ten's digit	FIC curve selection (1~5, same as FIV)			
Hundred's digit	Reserved			

The unit's digit, ten's digit and hundred's digit of this parameter are respectively used to select the corresponding curve of FIV, FIC and FIC. Any of the five curves can be selected for FIV, FIC and FIC.

Curve 1, curve 2 and curve 3 are all 2-point curves, set in group P5. Curve 4 and curve 5 are both 4-point curves, set in group C6.

The Z8000 provides two FI terminals as standard. FIA is provided by an optional extension Card.

P5.34	Setting for FI less than minimum input		Default	000
	Setting Range	Unit's digit	Setting for FIV less than minimum input	
		0	Minimum value	
		1	0.0%	
		Ten's digit	Setting for FIC less than minimum input (0~1, same as FIV)	
Hundred's digit	Reserved			

This parameter is used to determine the corresponding setting when the analog input voltage is less than the minimum value. The unit's digit, ten's digit and hundred's digit of this parameter respectively correspond to the setting for FIV, FIC and FIC.

If the value of a certain digit is 0, when analog input voltage is less than the minimum input, the corresponding setting of the minimum input (P5.14, P5.19, P5.24) is used.

If the value of a certain digit is 1, when analog input voltage is less than the minimum input, the corresponding value of this analog input is 0.0%

P5.35	X1 delay time		Default	0.0s
	Setting Range	0.0s~3600.0s		
P5.36	X2 delay time		Default	0.0s
	Setting Range	0.0s~600.0s		
P5.37	X3 delay time		Default	0.0s
	Setting Range	0.0s~3600.0s		

These parameters are used to set the delay time of the AC drive when the status of X terminals changes.

Currently, only X1, X2 and X3 support the delay time function.

P5.38	X valid mode selection 1		Default	00000
	Setting Range	Unit's digit	X1 valid mode	
		0	High level valid	
		1	Low level valid	
		Ten's digit	X2 valid mode (0~1, same as X1)	
		Hundred's digit	X3 valid mode (0~1, same as X1)	
		Thousand's digit	X4 valid mode (0~1, same as X1)	
Ten thousand's digit	X5 valid mode (0~1, same as X1)			
P5.39	X valid mode selection 2		Default	00000
	Setting Range	Unit's digit	X6 valid mode	
		0	High level valid	
		1	Low level valid	
		Ten's digit	X7 valid mode (0~1, same as X6)	
		Hundred's digit	X8 valid mode (0~1, same as X6)	
		Thousand's digit	Reserved	
Ten thousand's digit	Reserved			

These parameters are used to set the valid mode of X terminals.

0: High level valid

The X terminal is valid when being connected with COM, and invalid when being disconnected from COM.

1: Low level valid

The X terminal is invalid when being connected with COM, and invalid when being disconnected from COM.

## Group P6: Output Terminals

The Z8000 provides two multi-function analog output terminals FOV, FOC, two multi-function relay output terminals and a YO terminal (used for high-speed pulse output or open-collector switch signal output) as standard. If above output terminals can't satisfy the scene with application, requires the expansion card equipped with multi-function input and output.

P6.00	YO terminal output mode		Default	0
	Setting Range	0	Pulse output (YO-P)	
1		Switch signal output (YO-R)		

The YO terminal is programmable multiplexing terminal. It can be used for high-speed pulse output (YO-P), with maximum frequency of 50 kHz. Refer to P6.06 for relevant functions of Pulse output(YO-P). It can also be used as open collector switch signal output (YO-R).

P6.01	YO-R function (open-collector output terminal)	Default	0
P6.02	Relay output function (YA-YB-YC)	Default	2
P6.03	Relay output function (RA-RB-RC)	Default	0
P6.04	Reserved		
P6.05	Reserved		

These five parameters are used to select the functions of the five digital output terminals. RA-RB-RC and YA-YB-YC are respectively the relays on the control board and the extension card. The functions of the output terminals are described in the following table.  
Table 4-5 Functions of output terminals

Value	Function	Description
0	No output	The terminal has no function.
1	AC drive running	When the AC drive is running and has output frequency (can be zero), the terminal becomes ON.
2	Fault output (stop)	When the AC drive stops due to a fault, the terminal becomes ON.
3	Frequency-level detection FDT1 output	Refer to the descriptions of P8.19 and P8.20.
4	Frequency reached	Refer to the descriptions of P8.21.
5	Zero-speed running (no output at stop)	If the AC drive runs with the output frequency of 0, the terminal becomes ON. If the AC drive is in the stop state, the terminal becomes OFF.
6	Motor overload pre-warning	The AC drive judges whether the motor load exceeds the overload pre-warning threshold before performing the protection action. If the pre-warning threshold is exceeded, the terminal becomes ON. For motor overload parameters, see the descriptions of P9.00 to P9.02.
7	AC drive overload pre-warning	The terminal becomes ON 10s before the AC drive overload protection action is performed.
8	Set count value reached	The terminal becomes ON when the count value reaches the value set in Pb.08.
9	Designated count value reached	The terminal becomes ON when the count value reaches the value set in Pb.09.

Value	Function	Description
10	Length reached	The terminal becomes ON when the detected actual length exceeds the value set in Pb.05.
11	PLC cycle complete	When simple PLC completes one cycle, the terminal outputs a pulse signal with width of 250 ms.
12	Accumulative running time reached	If the accumulative running time of the AC drive exceeds the time set in P8.17, the terminal becomes ON.
13	Frequency limited	If the set frequency exceeds the frequency upper limit or lower limit and the output frequency of the AC drive reaches the upper limit or lower limit, the terminal becomes ON.
14	Torque limited	In speed control mode, if the output torque reaches the torque limit, the AC drive enters the stall protection state and meanwhile the terminal becomes ON.
15	Ready for RUN	If the AC drive main circuit and control circuit become stable, and the AC drive detects no fault and is ready for RUN, the terminal becomes ON.
16	FIV>FIC	When the input of FIV is larger than the input of FIC, the terminal becomes ON.
17	Frequency upper limit reached	If the running frequency reaches the upper limit, the terminal becomes ON.
18	Frequency lower limit reached (no output at stop)	If the running frequency reaches the lower limit, the terminal becomes ON. In the stop state, the terminal becomes OFF.
19	Under voltage state output	If the AC drive is in under voltage state, the terminal becomes ON.
20	Communication setting	Refer to the communication protocol.
21	Reserved	Reserved
22	Reserved	Reserved
23	Zero-speed running 2 (having output at stop)	If the output frequency of the AC drive is 0, the terminal becomes ON. In the state of stop, the signal is still ON.
24	Accumulative power-on time reached	If the AC drive accumulative power-on time (P7.13) exceeds the value set in P8.16, the terminal becomes ON.
25	Frequency level detection FDT2 output	Refer to the descriptions of P8.28 and P8.29.
26	Frequency 1 reached	Refer to the descriptions of P8.30 and P8.31.

Value	Function	Description
27	Frequency 2 reached	Refer to the descriptions of P8.32 and P8.33.
28	Current 1 reached	Refer to the descriptions of P8.38 and P8.39.
29	Current 2 reached	Refer to the descriptions of P8.40 and P8.41.
30	Timing reached	If the timing function (P8.42) is valid, the terminal becomes ON after the current running time of the AC drive reaches the set time.
31	FIV input limit exceeded	If FIV input is larger than the value of P9.46 (FIV input voltage upper limit) or lower than the value of P9.45 (FIV input voltage lower limit), the terminal becomes ON.
32	Load becoming 0	If the load becomes 0, the terminal becomes ON.
33	Reverse running	If the AC drive is in the reverse running state, the terminal becomes ON.
34	Zero current state	Refer to the descriptions of P8.28 and P8.29.
35	Module temperature reached	If the heatsink temperature of the inverter module (P7.07) reaches the set module temperature threshold (P8.47), the terminal becomes ON.
36	Software current limit exceeded	Refer to the descriptions of P8.36 and P8.37.
37	Frequency lower limit reached (having output at stop)	If the running frequency reaches the lower limit, the terminal becomes ON. In the stop state, the signal is still ON.
38	Alarm output	If a fault occurs on the AC drive and the AC drive continues to run, the terminal outputs the alarm signal.
39	Reserved	Reserved
40	Current running time reached	If the current running time of AC drive exceeds the value of P8.53, the terminal becomes ON.

P6.06	YO-P function selection	Default	0
P6.07	FOV function selection	Default	0
P6.08	FOC function selection	Default	1

The output pulse frequency of the YO-P terminal ranges from 0.01 kHz to "Maximum YO-P output frequency" (P6.09). The value of P6.09 is between 0.01 kHz and 100.00 kHz.

The output range of FOV and FOC is 0–10 V or 0–20 mA. The relationship between pulse and analog output ranges and corresponding functions is listed in the following table.

Table 4-6 Relationship between pulse and analog output ranges and corresponding functions.

Value	Function	Range (Corresponding to Pulse or Analog Output Range 0.0%~100.0%)
0	Running frequency	0~maximum output frequency
1	Set frequency	0~maximum output frequency
2	Output current	0~2 times of rated motor current
3	Output torque	0~2 times of rated motor torque
4	Output power	0~2 times of rated power
5	Output voltage	0~1.2 times of rated AC drive voltage
6	Pulse input	0.01kHz~100.00kHz
7	FIV	0V~10V
8	FIC	0V~10V (or 0~20mA)
9	Reserved	
10	Length	0~maximum set length
11	Count value	0~maximum count value
12	Communication setting	0.0%~100.0%
13	Motor rotational speed	0~rotational speed corresponding to maximum output frequency
14	Output current	0.0A~1000.0A
15	Output voltage	0.0V~1000.0V

P6.09	Maximum YO-P output	Default	50.00kHz
	Setting Range	0.01kHz~100.00kHz	

If the YO terminal is used for pulse output, this parameter is used to set the maximum frequency of pulse output.

P6.10	FOV offset coefficient	Default	0.0%
	Setting Range	-100.0%~+100.0%	
P6.11	FOV gain	Default	1.00
	Setting Range	-10.00~+10.00	
P6.12	FOC offset coefficient	Default	0.00%
	Setting Range	-100.0%~+100.0%	
P6.13	FOC gain	Default	1.00
	Setting Range	-10.00~+10.00	

These parameters are used to correct the zero drift of analog output and the output amplitude deviation. They can also be used to define the desired YO curve.

If "b" represents zero offset, "k" represents gain, "Y" represents actual output, and "X" represents standard output, the actual output is:  $Y = kX + b$ .

The zero offset coefficient 100% of FOV and FOC corresponds to 10 V (or 20 mA). The standard output refers to the value corresponding to the analog output of 0 to 10 V (or 0 to 20 mA) with no zero offset or gain adjustment.

For example, if the analog output is used as the running frequency, and it is expected that the output is 8 V when the frequency is 0 and 3 V at the maximum frequency, the gain shall be set to -0.50, and the zero offset shall be set to 80%.

P6.17	YO-R output delay time	Default	0.0s
	Setting Range	0.0s~3600.0s	
P6.18	YA-YB-YC output delay time	Default	0.0s
	Setting Range	0.0s~3600.0s	
P6.19	RA-RB-RC output delay time	Default	0.0s
	Setting Range	0.0s~3600.0s	
P6.20	Reserved		
P6.21	Reserved		

These parameters are used to set the delay time of output terminals YO-R, relay 1, relay 2, FOV and FOC from status change to actual output.

P6.22	YO valid mode selection	Default	00000
	Setting Range	Unit's digit	YO-R valid mode
		0	Positive logic
		1	Negative logic
		Ten's digit	YA-YB-YC valid mode (0~1, same as YO-R)
		Hundred's digit	RA-RB-RC valid mode (0~1, same as YO-R)
		Thousand's digit	Reserved
Ten thousand's digit	Reserved		

It is used to set the logic of output terminals YO-R, relay 1, relay 2, FOV and FOC.

0: Positive logic

The output terminal is valid when being connected with COM, and invalid when being disconnected from COM.

1: Negative logic

The output terminal is invalid when being connected with COM, and valid when being disconnected from COM.

**Group P7: Operation Panel and Display**

P7.00	Output power correction factor		Default	100.0
	Setting Range	0	0.0~200.0	
P7.01	JOG key function selection		Default	0
	Setting Range	0	JOG key disabled	
		1	Switchover between operation panel control and remote command control (terminal or communication)	
		2	Switchover between forward rotation and reverse rotation	
		3	Forward JOG	
		4	Reverse JOG	

JOG key refers to multifunctional key. You can set the function of the JOG key by using this parameter. You can perform switchover by using this key both in stop or running state.

0: JOG key disabled

This key is disabled.

1: Switchover between operation panel control and remote command control (terminal or communication).

You can perform switchover from the current command source to the operation panel control (local operation). If the current command source is operation panel control, this key is invalid.

2: Switchover between forward rotation and reverse rotation

You can change the direction of the frequency reference by using the JOG key. It is valid only when the current command source is operation panel control.

3: Forward JOG

You can perform forward JOG (JOG-FWD) by using the JOG key.

4: Reverse JOG

You can perform reverse JOG (JOG-REV) by using the JOG key.

P7.02	STOP/RESET key function		Default	1
	Setting Range	0	STOP/RESET key enabled only in operation panel control	
		1	STOP/RESET key enabled in any operation mode	

LED display running parameters 1		Default	1F
P7.03	Setting Range 0000 ~FFFF		
		<p>If a parameter needs to be displayed during the running, set the corresponding bit to 1, and set P7.03 to the hexadecimal equivalent of this binary number.</p>	

LED display running parameters 2		Default	0
P7.04	Setting Range 0000 ~FFFF	7 6 5 4 3 2 1 0	<ul style="list-style-type: none"> <li>— PID feedback</li> <li>— PLC stage</li> <li>— PULSE setting frequency (KHz)</li> <li>— Running frequency 2</li> <li>— Remaining running time</li> <li>— FIV voltage before correction</li> <li>— FIC current before correction</li> <li>— Reserved voltage before correction</li> </ul>
		15 14 13 12 11 10 9 8	<ul style="list-style-type: none"> <li>— Linear speed</li> <li>— current power-on time (Hour)</li> <li>— current running time (minute)</li> <li>— PULSE setting frequency (Hz)</li> <li>— Communication setting value</li> <li>— Encoder feedback speed (Hz)</li> <li>— Main frequency X display (Hz)</li> <li>— Auxiliary frequency Y display (Hz)</li> </ul> <p>If a parameter needs to be displayed during the running, set the corresponding bit to 1, and set P7.04 to the hexadecimal equivalent of this binary number.</p>

These two parameters are used to set the parameters that can be viewed when the AC drive is in the running state. You can view a maximum of 32 running state parameters that are displayed from the lowest bit of P7.03.

LED display stop parameters		Default	33
P7.05	Setting Range 0000 ~FFFF		
		If a parameter needs to be displayed during the running, set the corresponding bit to 1, and set P7.05 to the hexadecimal equivalent of this binary number.	

P7.06	Load speed display coefficient	Default	1.0000
	Setting Range	0.0001~6.5000	

This parameter is used to adjust the relationship between the output frequency of the AC drive and the load speed. For details, see the description of P7.12.

P7.07	Heatsink temperature of inverter	Default	Read-only
	Setting Range	0.0°C~150.0°C	

It is used to display the insulated gate bipolar transistor (IGBT) temperature of the inverter module, and the IGBT overheat protection value of the inverter module depends on the model.

P7.08	Temporary software version	Default	Read-only
	Setting Range	0.0°C~150.0°C	

It is used to display the temporary software version of the control board.

P7.09	Accumulative running time	Default	0h
	Setting Range	0h~65535h	

It is used to display the accumulative running time of the AC drive. After the accumulative running time reaches the value set in P8.17, the terminal with the digital output function 12 becomes ON.

P7.10	reserve	Default	
P7.11	Software version	Default	Read-only
	Setting Range	Software version of control board	
P7.12	Number of decimal places for load speed display	Default	0
	Setting Range	0	0 decimal place
		1	1 decimal place
		2	2 decimal places
		3	3 decimal places

P7.12 is used to set the number of decimal places for load speed display. The following gives an example to explain how to calculate the load speed:

Assume that P7.06 (Load speed display coefficient) is 2.000 and P7.12 is 2 (2 decimal places). When the running frequency of the AC drive is 40.00 Hz, the load speed is  $40.00 \times 2.000 = 80.00$  (display of 2 decimal places).

If the AC drive is in the stop state, the load speed is the speed corresponding to the set frequency, namely, "set load speed". If the set frequency is 50.00 Hz, the load speed in the stop state is  $50.00 \times 2.000 = 100.00$  (display of 2 decimal places).

P7.13	Accumulative power-on time	Default	0h
	Setting Range	0h~65535h	

It is used to display the accumulative power-on time of the AC drive since the delivery. If the time reaches the set power-on time (P8.17), the terminal with the digital output function 24 becomes ON.

P7.14	Accumulative power consumption	Default	-
	Setting Range	0~65535kWh	

It is used to display the accumulative power consumption of the AC drive until now.

**Group P8: Auxiliary Functions**

P8.00	OG running frequency	Default	2.00Hz
	Setting Range	0.00Hz~maximum frequency	
P8.01	JOG acceleration time	Default	20.0s
	Setting Range	0.0s~6500.0s	
P8.02	JOG deceleration time	Default	20.0s
	Setting Range	0.0s~6500.0s	

These parameters are used to define the set frequency and acceleration/deceleration time of the AC drive when jogging. The startup mode is "Direct start" (P1.00 = 0) and the stop mode is "Decelerate to stop" (P1.10 = 0) during jogging.

P8.03	Acceleration time 2	Default	Model dependent
	Setting Range	0.0s~6500.0s	
P8.04	Deceleration time 2	Default	Model dependent
	Setting Range	0.0s~6500.0s	
P8.05	Acceleration time 3	Default	Model dependent
	Setting Range	0.0s~6500.0s	
P8.06	Deceleration time 3	Default	Model dependent
	Setting Range	0.0s~6500.0s	
P8.07	Acceleration time 4	Default	Model dependent
	Setting Range	0.0s~6500.0s	
P8.08	Deceleration time 4	Default	Model dependent
	Setting Range	0.0s~6500.0s	

The Z8000 provides a total of four groups of acceleration/deceleration time, that is, the preceding three groups and the group defined by P0.17 and P0.18. Definitions of four groups are completely the same. You can switch over between the four groups of acceleration/deceleration time through different state combinations of X terminals. For more details, see the descriptions of P5.01 to P5.05.

P8.09	Jump frequency 1	Default	0.00Hz
	Setting Range	0.00Hz~maximum frequency	
P8.10	Jump frequency 2	Default	0.00Hz
	Setting Range	0.00 Hz~maximum frequency	
P8.11	Frequency jump amplitude	Default	0.00Hz
	Setting Range	0.00~maximum frequency	

If the set frequency is within the frequency jump range, the actual running frequency is the jump frequency close to the set frequency. Setting the jump frequency helps to avoid the mechanical resonance point of the load.

The Z8000 supports two jump frequencies. If both are set to 0, the frequency jump function is disabled. The principle of the jump frequencies and jump amplitude is shown in the following figure.

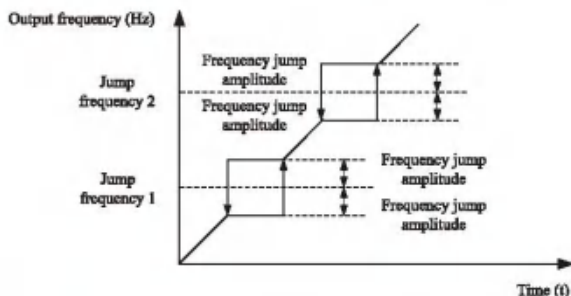

Figure 4-12 Principle of the jump frequencies and jump amplitude

P8.12	Forward/Reverse rotation dead-zone time	Default	0.0s
	Setting Range	0.00s~3000.0s	

It is used to set the time when the output is 0 Hz at transition of the AC drive forward rotation and reverse rotation, as shown in the following figure.

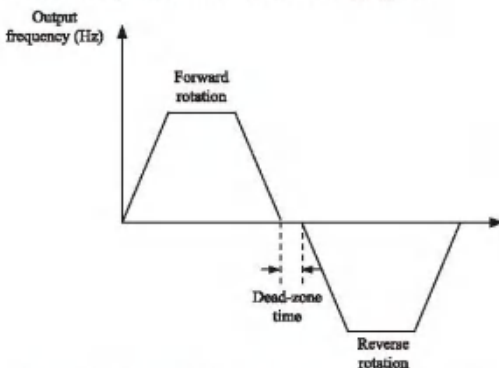

Figure 4-13 Forward/Reverse rotation dead-zone time

P8.13	Reverse control		Default	0
	Setting Range	0	Enabled	
		1	Disabled	

It is used to set whether the AC drive allows reverse rotation. In the applications where reverse rotation is prohibited, set this parameter to 1.

P8.14	Running mode when set frequency lower than frequency lower limit		Default	0
	Setting Range	0	Run at frequency lower limit	
		1	Stop	
		2	Run at zero speed	

It is used to set the AC drive running mode when the set frequency is lower than the frequency lower limit. The Z8000 provides three running modes to satisfy requirements of various applications.

P8.15	Droop control		Default	0.00Hz
	Setting Range	0.00Hz~10.00Hz		

This function is used for balancing the workload allocation when multiple motors are used to drive the same load. The output frequency of the AC drives decreases as the load increases. You can reduce the workload of the motor under load by decreasing the output frequency for this motor, implementing workload balancing between multiple motors.

P8.16	Accumulative power-on time threshold		Default	0h
	Setting Range	0h~65000h		

If the accumulative power-on time (P7.13) reaches the value set in this parameter, the corresponding Y terminal becomes ON.

P8.17	Accumulative running time threshold		Default	0h
	Setting Range	0h~65000h		

It is used to set the accumulative running time threshold of the AC drive. If the accumulative running time (P7.09) reaches the value set in this parameter, the corresponding YO terminal becomes ON.

P8.18	Startup protection		Default	0
	Setting Range	0	No	
		1	Yes	

This parameter is used to set whether to enable the safety protection. If it is set to 1, the AC drive does not respond to the run command valid upon AC drive power-on (for example, an input terminal is ON before power-on). The AC drive responds only after

the run command is cancelled and becomes valid again.

In addition, the AC drive does not respond to the run command valid upon fault reset of the AC drive. The run protection can be disabled only after the run command is cancelled.

In this way, the motor can be protected from responding to run commands upon power-on or fault reset in unexpected conditions.

P8.19	Frequency detection value (FDT1)	Default	50.00Hz
	Setting Range	0.00Hz~maximum frequency	
P8.20	Frequency detection hysteresis (FDT1)	Default	5.0%
	Setting Range	0.0%~100.0% (FDT1 level)	

If the running frequency is higher than the value of P8.19, the corresponding YO terminal becomes ON. If the running frequency is lower than value of P8.19, the YO terminal goes OFF.

These two parameters are respectively used to set the detection value of output frequency and hysteresis value upon cancellation of the output. The value of P8.20 is a percentage of the hysteresis frequency to the frequency detection value (P8.19). The FDT function is shown in the following figure.

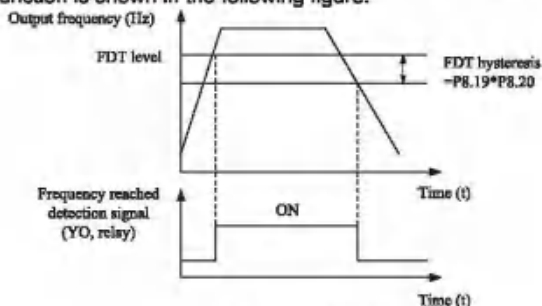

Figure 4-14 FDT level

P8.21	Detection range of frequency reached	Default	0.0%
	Setting Range	0.00~100% (maximum frequency)	

If the AC drive running frequency is within the certain range of the set frequency, the corresponding YO terminal becomes ON.

This parameter is used to set the range within which the output frequency is detected to reach the set frequency. The value of this parameter is a percentage relative to the maximum frequency. The detection range of frequency reached is shown in the following

figure.

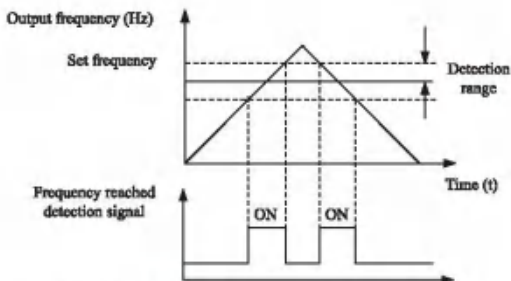

Figure 4-15 Detection range of frequency reached

P8.22	Jump frequency during acceleration/deceleration	Default	1
	Setting Range	0: Disabled 1: Enabled	

It is used to set whether the jump frequencies are valid during acceleration/deceleration.

When the jump frequencies are valid during acceleration/deceleration, and the running frequency is within the frequency jump range, the actual running frequency will jump over the set frequency jump amplitude (rise directly from the lowest jump frequency to the highest jump frequency). The following figure shows the diagram when the jump frequencies are valid during acceleration/deceleration.

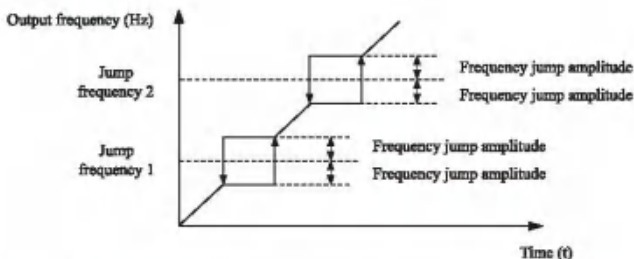

Figure 4-16 Diagram when the jump frequencies are valid during acceleration/deceleration

P8.25	Frequency switchover point between acceleration time 1 and acceleration time 2	Default	0.00Hz
	Setting Range	0.00Hz~maximum frequency	
P8.26	Frequency switchover point between deceleration time 1 and deceleration time 2	Default	0.00Hz
	Setting Range	0.00Hz~maximum frequency	

This function is valid when motor 1 is selected and acceleration/deceleration time switchover is not performed by means of X terminal. It is used to select different groups of acceleration/deceleration time based on the running frequency range rather than X terminal during the running process of the AC drive.

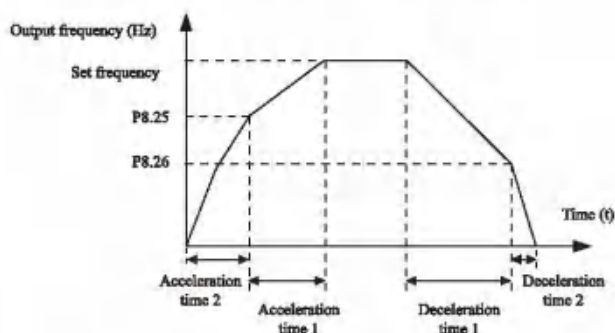

Figure 4-17 Acceleration/deceleration time switchover

During acceleration, if the running frequency is smaller than the value of P8.25, acceleration time 2 is selected. If the running frequency is larger than the value of P8.25, acceleration time 1 is selected.

During deceleration, if the running frequency is larger than the value of P8.26, deceleration time 1 is selected. If the running frequency is smaller than the value of P8.26, deceleration time 2 is selected.

P8.27	Terminal JOG preferred	Default	0
	Setting Range	0: Disabled 1: Enabled	

It is used to set whether terminal JOG is preferred.

If terminal JOG is preferred, the AC drive switches to terminal JOG running state when there is a terminal JOG command during the

running process of the AC drive.

P8.28	Frequency detection value (FDT2)	Default	50.00Hz
	Setting Range	0.00Hz~maximum frequency	
P8.29	Frequency detection hysteresis (FDT2)	Default	5.0%
	Setting Range	0.0%~100.0% (FDT2 level)	

The frequency detection function is the same as FDT1 function. For details, refer to the descriptions of P8.19 and FP8.20.

P8.30	Any frequency reaching detection value 1	Default	50.00Hz
	Setting Range	0.00 Hz~ maximum frequency	
P8.31	Any frequency reaching detection amplitude 1	Default	0.0%
	Setting Range	0.0%~100.0% (maximum frequency)	
P8.32	Any frequency reaching detection value 2	Default	50.00Hz
	Setting Range	0.00Hz~maximum frequency	
P8.33	Any frequency reaching detection amplitude 2	Default	0.0%
	Setting Range	0.0%~100.0% (maximum frequency)	

If the output frequency of the AC drive is within the positive and negative amplitudes of the any frequency reaching detection value, the corresponding YO becomes ON.

The Z8000 provides two groups of any frequency reaching detection parameters, including frequency detection value and detection amplitude, as shown in the following figure.

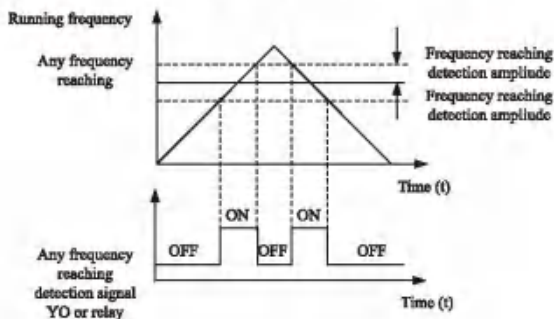

Figure 4-18 Any frequency reaching detection

P8.34	Zero current detection level	Default	5.0%
	Setting Range	0.0%~300.0% (rated motor current)	
P8.35	Zero current detection delay time	Default	0.10s
	Setting Range	0.01s~600.00s	

If the output current of the AC drive is equal to or less than the zero current detection level and the duration exceeds the zero current detection delay time, the corresponding YO becomes ON. The zero current detection is shown in the following figure

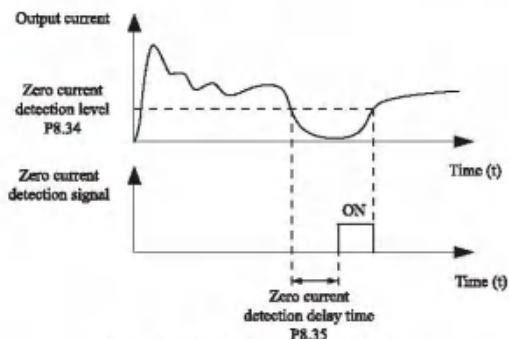

Figure 4-19 Zero current detection

P8.36	Output over current threshold	Default	200.0%
	Setting Range	0.0% (no detection) 0.1%~300.0% (rated motor current)	
P8.37	Output over current detection delay time	Default	0.00s
	Setting Range	0.00s~600.00s	

If the output current of the AC drive is equal to or higher than the over current threshold and the duration exceeds the detection delay time, the corresponding YO becomes ON. The output over current detection function is shown in the following figure.

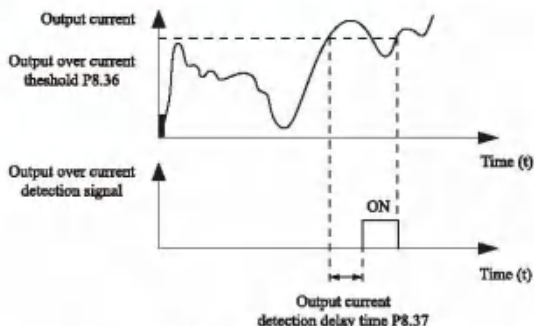

Figure 4-20 Output over current detection

P8.38	Any current reaching 1	Default	100.0%
	Setting Range	0.0%~300.0% (rated motor current)	
P8.39	Any current reaching 1 amplitude	Default	0.0%
	Setting Range	0.0%~300.0% (rated motor current)	
P8.40	Any current reaching 2	Default	100.0%
	Setting Range	0.0%~300.0% (rated motor current)	
P8.41	Any current reaching 2 amplitude	Default	0.0%
	Setting Range	0.0%~300.0% (rated motor current)	

If the output current of the AC drive is within the positive and negative amplitudes of any current reaching detection value, the corresponding YO becomes ON.

The Z8000 provides two groups of any current reaching detection parameters, including current detection value and detection amplitudes, as shown in the following figure.

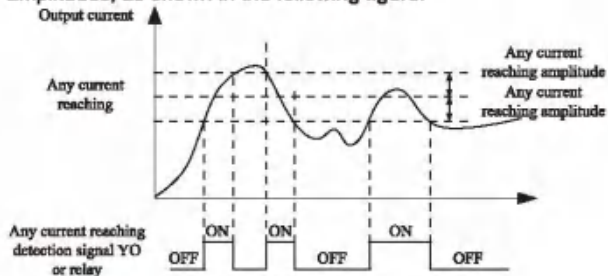

Figure 4-21 Any current reaching detection

P8.42	Timing function		Default	0
	Setting Range	0	Disabled	
1		Enabled		
P8.43	Timing duration source		Default	0
	Setting Range	0	P8.44	
		1	FIV	
		2	FIC	
		3	Reserved	
100% of analog Input corresponds to the value of P8.44				
P8.44	Timing duration		Default	0.0Min
	Setting Range		0.0Min~6500.0Min	

These parameters are used to implement the AC drive timing function.

If P8.42 is set to 1, the AC drive starts to time at startup. When the set timing duration is reached, the AC drive stops automatically and meanwhile the corresponding YO becomes ON.

The AC drive starts timing from 0 each time it starts up and the remaining timing duration can be queried by D0.20. The timing duration is set in P8.43 and P8.44, in unit of minute.

P8.45	FIV input voltage lower limit		Default	3.10V
	Setting Range		0.00V~P8.46	
P8.46	FIV input voltage upper limit		Default	6.80V
	Setting Range		P8.45~10.00V	

These two parameters are used to set the limits of the input voltage to provide protection on the AC drive. When the FIV input is larger than the value of P8.46 or smaller than the value of P8.45, the corresponding YO becomes ON, indicating that FIV input exceeds the limit.

P8.47	Module temperature		Default	100°C
	Setting Range		0~150°C	

When the heat sink temperature of the AC drive reaches the value of this parameter, the corresponding YO becomes ON, indicating that the module temperature reaches the threshold.

P8.48	Cooling fan control		Default	0
	Setting Range		0: Fan working during running 1: Fan working continuously	

It is used to set the working mode of the cooling fan. If this parameter is set to 0, the fan works when the AC drive is in running state. When the AC drive stops, the cooling fan works if the heat sink temperature is higher than 40°C, and stops working if the heat

sink temperature is lower than 40°C.

If this parameter is set to 1, the cooling fan keeps working after power-on.

P8.49	Wakeup frequency	Default	0.00Hz
	Setting Range	Dormant frequency (P8.51) ~maximum frequency (P0.12)	
P8.50	Wakeup delay time	Default	0.0s
	Setting Range	0.0s~6500.0s	
P8.51	Dormant frequency	Default	0.00Hz
	Setting Range	0.00Hz~wakeup frequency (P8.49)	
P8.52	Dormant delay time	Default	0.0s
	Setting Range	0.0s~6500.0s	

These parameters are used to implement the dormant and wakeup functions in the water supply application.

When the AC drive is in running state, the AC drive enters the dormant state and stops automatically after the dormant delay time (P9.52) if the set frequency is lower than or equal to the dormant frequency (P9.51).

When the AC drive is in dormant state and the current running command is effective, the AC drives starts up after the wakeup delay time (P9.50) if the set frequency is higher than or equal to the wakeup frequency (P9.49).

Generally, set the wakeup frequency equal to or higher than the dormant frequency. If the wakeup frequency and dormant frequency are set to 0, the dormant and wakeup functions are disabled.

When the dormant function is enabled, if the frequency source is PID, whether PID operation is performed in the dormant state is determined by PA.28. In this case, select PID operation enabled in the stop state (PA.28 = 1).

P8.53	Current running time reached	Default	0.0Min
	Setting Range	0.0Min~6500.0Min	

If the current running time reaches the value set in this parameter, the corresponding YO becomes ON, indicating that the current running time is reached.

## Group P9: Fault and Protection

P9.00	Motor overload protection selection	Default	1
	Setting Range	0	Disabled
		1	Enabled

P9.01	Motor overload protection gain	Default	1.00
	Setting Range	0.20~10.00	

P9.00 = 0

The motor overload protective function is disabled. The motor is exposed to potential damage due to overheating. A thermal relay is suggested to be installed between the AC drive and the motor.

P9.00 = 1

The AC drive judges whether the motor is overloaded according to the inverse time-lag curve of the motor overload protection.

The inverse time-lag curve of the motor overload protection is:

220% x P9.01 x rated motor current (if the load remains at this value for one minute, the AC drive reports motor overload fault), or 150% x P9.01 x rated motor current (if the load remains at this value for 60 minutes, the AC drive reports motor overload fault).

Set P9.01 properly based on the actual overload capacity. If the value of P9.01 is set too large, damage to the motor may result because the motor overheats but the AC drive does not report the alarm.

P9.02	Motor overload warning coefficient	Default	80%
	Setting Range	50%~100%	

This function is used to give a warning signal to the control system via YO before motor overload protection. This parameter is used to determine the percentage, at which pre-warning is performed before motor overload. The larger the value is, the less advanced the pre-warning will be.

When the accumulative output current of the AC drive is greater than the value of the overload inverse time-lag curve multiplied by P9.02, the YO terminal on the AC drive allocated with function 6 (Motor overload pre-warning) becomes ON.

P9.03	Overvoltage stall gain	Default	10
	Setting Range	0 (no stall overvoltage) ~100	
P9.04	Overvoltage stall protective voltage	Default	130%
	Setting Range	120%~150% (Three phase)	

When the DC bus voltage exceeds the value of P9.04 (Overvoltage stall protective voltage) during deceleration of the AC drive, the AC drive stops deceleration and keeps the present running frequency. After the bus voltage declines, the AC drive

continues to decelerate. P9.03 (Overvoltage stall gain) is used to adjust the overvoltage suppression capacity of the AC drive. The larger the value is, the greater the overvoltage suppression capacity will be.

In the prerequisite of no overvoltage occurrence, set P9.03 to a small value.

For small-inertia load, the value should be small. Otherwise, the system dynamic response will be slow. For large-inertia load, the value should be large. Otherwise, the suppression result will be poor and an overvoltage fault may occur. If the overvoltage stall gain is set to 0, the overvoltage stall function is disabled.

P9.05	Over current stall gain	Default	20
	Setting Range	0~100	
P9.06	Over current stall protective current	Default	150%
	Setting Range	100%~200%	

When the output current exceeds the over current stall protective current during acceleration/deceleration of the AC drive, the AC drive stops acceleration/deceleration and keeps the present running frequency. After the output current declines, the AC drive continues to accelerate/decelerate.

P9.05 (Over current stall gain) is used to adjust the over current suppression capacity of the AC drive. The larger the value is, the greater the over current suppression capacity will be. In the prerequisite of no over current occurrence, set P9.05 to a small value.

For small-inertia load, the value should be small. Otherwise, the system dynamic response will be slow. For large-inertia load, the value should be large. Otherwise, the suppression result will be poor and over current fault may occur. If the over current stall gain is set to 0, the over current stall function is disabled.

P9.07	Short-circuit to ground upon power-on	Default	1
	Setting Range	0	Disabled
		1	Enabled

It is used to determine whether to check the motor is short-circuited to ground at power-on of the AC drive. If this function is enabled, the AC drive's UVW will have voltage output a while after power-on.

P9.09	Fault auto reset times	Default	0
	Setting Range	0~20	

It is used to set the times of fault auto resets if this function is used.

After the value is exceeded, the AC drive will remain in the fault state.

P9.10	YO action during fault auto reset	Default	0
	Setting Range	0: Not act 1: Act	

It is used to decide whether the YO acts during the fault auto reset if the fault auto reset function is selected.

P9.11	Time interval of fault auto reset	Default	1.0s
	Setting Range	0.1s~100.0s	

It is used to set the waiting time from the alarm of the AC drive to fault auto reset.

P9.12	Input phase loss protection selection	Default	1
	Setting Range	Unit's digit: Input phase loss protection 0: Disabled 1: Enabled Ten's digit: reserve	

It is used to determine whether to perform input phase loss or contactor energizing protection. Z8000 11 kw inverter type G machine and above power, just have the input phase protection function, 11 kw G type machines under power, no matter P9.12 set to 0 or 1 are no input phase protection function.

P9.13	Output phase loss protection selection	Default	1
	Setting Range	0: Disabled 1: Enabled	

It is used to determine whether to perform output phase loss protection.

P9.14	1st fault type	0~99
P9.15	2nd fault type	
P9.16	3rd (latest) fault type	

It is used to record the types of the most recent three faults of the AC drive. 0 indicates no fault. For possible causes and solution of each fault, refer to Chapter 8.

P9.17	Frequency upon 3rd fault	It displays the frequency when the latest fault occurs.
P9.18	Current upon 3rd fault	It displays the current when the latest fault occurs.
P9.19	Bus voltage upon 3rd fault	It displays the bus voltage when the latest fault occurs.

P9.20	Input terminal status upon 3rd fault	It displays the status of all input terminals when the latest fault occurs. The sequence is as follows: <table border="1" style="margin-left: 20px;"> <thead> <tr> <th>BIT9</th> <th>BIT8</th> <th>BIT7</th> <th>BIT6</th> <th>BIT5</th> <th>BIT4</th> <th>BIT3</th> <th>BIT2</th> <th>BIT1</th> <th>BIT0</th> </tr> </thead> <tbody> <tr> <td></td> <td></td> <td>X8</td> <td>X7</td> <td>X6</td> <td>X5</td> <td>X4</td> <td>X3</td> <td>X2</td> <td>X1</td> </tr> </tbody> </table> If a X is ON, the setting is 1. If the X is OFF, the setting is 0. The value is the equivalent decimal number converted from the X status.	BIT9	BIT8	BIT7	BIT6	BIT5	BIT4	BIT3	BIT2	BIT1	BIT0			X8	X7	X6	X5	X4	X3	X2	X1
BIT9	BIT8	BIT7	BIT6	BIT5	BIT4	BIT3	BIT2	BIT1	BIT0													
		X8	X7	X6	X5	X4	X3	X2	X1													
P9.21	Output terminal status upon 3rd fault	It displays the status of all output terminals when the latest fault occurs. The sequence is as follows: <table border="1" style="margin-left: 20px;"> <thead> <tr> <th>BIT4</th> <th>BIT3</th> <th>BIT2</th> <th>BIT1</th> <th>BIT0</th> </tr> </thead> <tbody> <tr> <td></td> <td></td> <td>YA,YB,YC</td> <td>RA,RB,RC</td> <td>YO</td> </tr> </tbody> </table> If an output terminal is ON, the setting is 1. If the output terminal is OFF, the setting is 0. The value is the equivalent decimal number converted from the X statuses.	BIT4	BIT3	BIT2	BIT1	BIT0			YA,YB,YC	RA,RB,RC	YO										
BIT4	BIT3	BIT2	BIT1	BIT0																		
		YA,YB,YC	RA,RB,RC	YO																		
P9.22	AC drive status upon 3rd fault	Reserved																				
P9.23	Power-on time upon 3rd fault	It displays the present power-on time when the latest fault occurs.																				
P9.24	Running time upon 3rd fault	It displays the present running time when the latest fault occurs.																				
P9.27	Frequency upon 2nd fault	Same as P9.17~P9.24																				
P9.28	Current upon 2nd fault																					
P9.29	Bus voltage upon 2nd fault																					
P9.30	X status upon 2nd fault																					
P9.31	Output terminal status upon 2nd fault																					
P9.32	Frequency upon 2nd fault																					
P9.33	Current upon 2nd fault																					
P9.34	Bus voltage upon 2nd fault	Same as P9.17~P9.24																				
P9.37	X status upon 1st fault																					
P9.38	Output terminal status upon 1st fault																					
P9.39	Frequency upon 1st fault																					
P9.40	Current upon 1st fault																					
P9.41	Bus voltage upon 3rd fault																					
P9.42	X status upon 1st fault																					
P9.43	Output terminal status upon 1st fault																					
P9.44	Frequency upon 1st fault																					

P9.47	Fault protection action selection 1		Default	00000
	Setting Range	Unit's digit	Motor overload (OL1)	
		0	Coast to stop	
		1	Stop according to the stop mode	
		2	Continue to run	
		Ten's digit	Power input phase loss (LI) (Same as unit's digit)	
		Hundred's digit	Power output phase loss (LO) (Same as unit's digit)	
		Thousand's digit	External equipment fault (EF) (Same as unit's digit)	
Ten thousand's digit		Communication fault (CE) (Same as unit's digit)		
P9.48	Fault protection action selection 2		Default	00000
	Setting Range	Unit's digit	Encoder fault (PG)	
		0	Coast to stop	
		1	Switch over to V/F control, stop according to the	
		2	stop mode	
		Ten's digit	Switch over to V/F control, continue to run EEPROM read-write fault (EEP)	
		0	Coast to stop	
		1	Stop according to the stop mode	
		Hundred's digit	reserved	
		Thousand's digit	Motor overheat (Same as unit's digit in P9.47)	
Ten thousand's digit		Accumulative running time reached (END1) (Same as unit's digit in P9.47)		

P9.49	Fault protection action selection 3		Default	00000
	Setting Range	Unit's digit	reserved	
		Ten's digit	reserved	
		Hundred's digit	Accumulative power-on time reached (END2) (Same as unit's digit in P9.47)	
		Thousand's digit	Load becoming 0 (LOAD)	
		0	Coast to stop	
		1	Stop according to the stop mode	
		2	Continue to run at 7% of rated motor frequency and resume to the set frequency if the load recovers	
Ten thousand's digit	PID feedback lost during running (PIDE) (Same as unit's digit in P9.47)			
P9.50	Fault protection action selection 4		Default	00000
	Setting Range	Unit's digit	Too large speed deviation (ESP) (Same as unit's digit in P9.47)	
		Ten's digit	Motor over-speed (OSP) (Same as unit's digit in P9.47)	
		Hundred's digit	Initial position fault (INI) (Same as unit's digit in P9.47)	
		Thousand's digit	reserved	
		Ten thousand's digit	Reserved	

If "Coast to stop" is selected, the AC drive displays error code and directly stops.

If "Stop according to the stop mode" is selected, the AC drive displays A\*\* and stops according to the stop mode. After stop, the AC drive displays error code.

If "Continue to run" is selected, the AC drive continues to run and displays A\*\*. The running frequency is set in P9.54.

P9.54	Frequency selection for continuing to run		Default	0
	Setting Range	0	Current running frequency	
		1	Set frequency	
		2	Frequency upper limit	
		3	Frequency lower limit	
		4	Backup frequency upon abnormality	

P9.55	Backup frequency upon abnormality	Default	100.0%
	Setting Range	60.0%~100.0%	

If a fault occurs during the running of the AC drive and the handling of fault is set to "Continue to run", the AC drive displays A\*\* and continues to run at the frequency set in P9.54.

The setting of P9.55 is a percentage relative to the maximum frequency.

P9.56	reserved		
P9.57	reserved		
P9.58	reserved		
P9.59	Action selection at instantaneous power failure	Default	0
	Setting Range	0	Invalid
		1	Decelerate
		2	Decelerate to stop
P9.60	Action pause judging voltage at instantaneous power failure	Default	90.0%
	Setting Range	0.0%~100.0%	
P9.61	Voltage rally judging time at instantaneous power failure	Default	0.50s
	Setting Range	0.00s~100.00s	
P9.62	Action judging voltage at instantaneous power failure	Default	80.0%
	Setting Range	60.0%~100.0% (standard bus voltage)	

Upon instantaneous power failure or sudden voltage dip, the DC bus voltage of the AC drive reduces. This function enables the AC drive to compensate the DC bus voltage reduction with the load feedback energy by reducing the output frequency so as to keep the AC drive running continuously.

If P9.59 = 1, upon instantaneous power failure or sudden voltage dip, the AC drive decelerates. Once the bus voltage resumes to normal, the AC drive accelerates to the set frequency. If the bus voltage remains normal for the time exceeding the value set in P9.61, it is considered that the bus voltage resumes to normal.

If P9.59 = 2, upon instantaneous power failure or sudden voltage dip, the AC drive decelerates to stop.

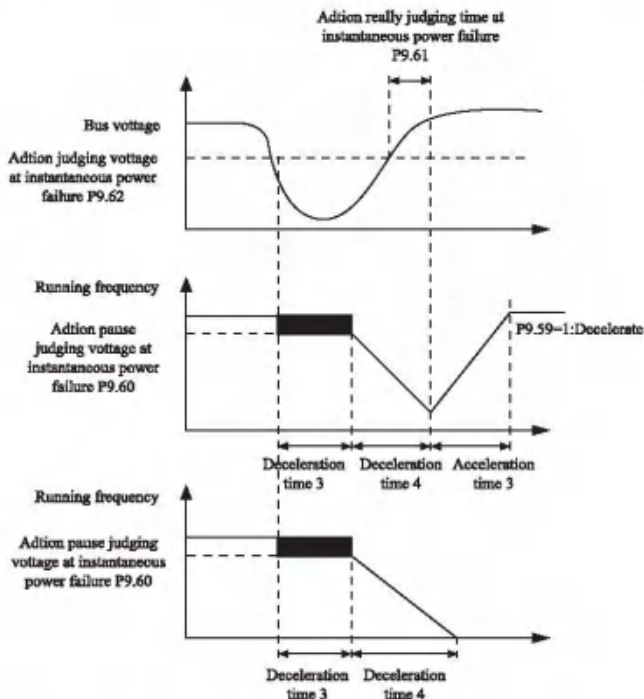

Figure 4-22 AC drive action diagram upon instantaneous power failure

P9.63	Protection upon load becoming 0	Default	0
	Setting Range	0	Disabled
		1	Enabled
P9.64	Detection level of load becoming 0	Default	10.0%
	Setting Range	0.0%~100.0% (rated motor current)	
P9.65	Detection time of load becoming 0	Default	1.0s
	Setting Range	0.0s~60.0s	

If protection upon load becoming 0 is enabled, when the output current of the AC drive is lower than the detection level (P9.64) and the lasting time exceeds the detection time (P9.65), the output

frequency of the AC drive automatically declines to 7% of the rated frequency. During the protection, the AC drive automatically accelerates to the set frequency if the load resumes to normal.

P9.67	Over-speed detection value	Default	20%
	Setting Range	0.0%~50.0% (maximum frequency)	
P9.68	Over-speed detection time	Default	1.0s
	Setting Range	0.0s~60.0s	

This function is valid only when the AC drive runs in the CLVC mode.

If the actual motor rotational speed detected by the AC drive exceeds the maximum frequency and the excessive value is greater than the value of P9.67 and the lasting time exceeds the value of P9.68, the AC drive reports OSP and acts according to the selected fault protection action. If the over-speed detection time is 0.0s, the over-speed detection function is disabled.

P9.69	Detection value of too large speed deviation	Default	20.0%
	Setting Range	0.0%~50.0% (maximum frequency)	
P9.70	Detection time of too large speed deviation	Default	5.0s
	Setting Range	0.0s~60.0s	

This function is valid only when the AC drive runs in the CLVC mode.

If the AC drive detects the deviation between the actual motor rotational speed detected by the AC drive and the set frequency is greater than the value of P9.69 and the lasting time exceeds the value of P9.70, the AC drive reports ESP and according to the selected fault protection action. If P9.70 (Detection time of too large speed deviation) is 0.0s, this function is disabled.

### Group PA: Process Control PID Function

PID control is a general process control method. By performing proportional, integral and differential operations on the difference between the feedback signal and the target signal, it adjusts the output frequency and constitutes a feedback system to stabilize the controlled counter around the target value.

It is applied to process control such as flow control, pressure control and temperature control. The following figure shows the principle block diagram of PID control.

PA.00	PID setting source		Default	0
	Setting Range	0	PA.01	
1		FIV		
2		FIC		
3		Reserved		
4		PULSE setting (X5)		
5		Communication setting		
6		Multi-reference		
PA.01	PID digital setting		Default	50.0%
	Setting Range		0.0%~100.0%	

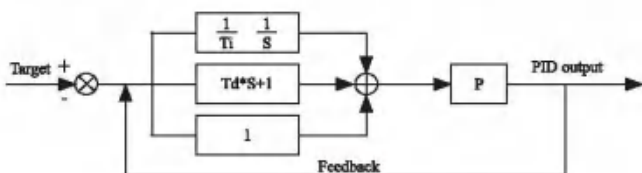

Figure 4-23 Principle block diagram of PID control

PA.00 is used to select the channel of target process PID setting. The PID setting is a relative value and ranges from 0.0% to 100.0%. The PID feedback is also a relative value. The purpose of PID control is to make the PID setting and PID feedback equal.

PA.02	PID feedback source		Default	0
	Setting Range	0	FIV	
1		FIC		
2		Reserved		
3		FIV~FIC		
4		PULSE setting (X5)		
5		Communication setting		
6		FIV+FIC		
7		MAX ( FIV , FIC )		
8		MIN ( FIV , FIC )		

This parameter is used to select the feedback signal channel of process PID.

The PID feedback is a relative value and ranges from 0.0% to 100.0%.

PA.03	PID action direction		Default	0
	Setting Range	0	Forward action	
1		Reverse action		

0: Forward action

When the feedback value is smaller than the PID setting, the AC drive's output frequency rises. For example, the winding tension control requires forward PID action.

#### 1: Reverse action

When the feedback value is smaller than the PID setting, the AC drive's output frequency reduces. For example, the unwinding tension control requires reverse PID action. Note that this function is influenced by the X function 35 "Reverse PID action direction".

PA.04	PID setting feedback range	Default	1000
	Setting Range	0~65535	

This parameter is a non-dimensional unit. It is used for PID setting display (D0.15) and PID feedback display (D0.16).

Relative value 100% of PID setting feedback corresponds to the value of PA.04. If PA.04 is set to 2000 and PID setting is 100.0%, the PID setting display (D0.15) is 2000.

PA.05	Proportional gain Kp1	Default	20.0
	Setting Range	0.0~100.0	
PA.06	Integral time T11	Default	2.00s
	Setting Range	0.01s~10.00s	
PA.07	Differential time Td1	Default	0.000s
	Setting Range	0.00~10.000	

#### PA.05 (Proportional gain Kp1)

It decides the regulating intensity of the PID regulator. The higher the Kp1 is, the larger the regulating intensity is. The value 100.0 indicates when the deviation between PID feedback and PID setting is 100.0%, the adjustment amplitude of the PID regulator on the output frequency reference is the maximum frequency.

#### PA.06 (Integral time T11)

It decides the integral regulating intensity. The shorter the integral time is, the larger the regulating intensity is. When the deviation between PID feedback and PID setting is 100.0%, the integral regulator performs continuous adjustment for the time set in PA.06. Then the adjustment amplitude reaches the maximum frequency.

#### PA.07 (Differential time Td1)

It decides the regulating intensity of the PID regulator on the deviation change. The longer the differential time is, the larger the regulating intensity is. Differential time is the time within which the feedback value change reaches 100.0%, and then the adjustment amplitude reaches the maximum frequency.

PA.08	Cut-off frequency of PID reverse rotation	Default	2.00Hz
	Setting Range	0.00~maximum frequency	

In some situations, only when the PID output frequency is a negative value (AC drive reverse rotation), PID setting and PID feedback can be equal. However, too high reverse rotation frequency is prohibited in some applications, and PA.08 is used to determine the reverse rotation frequency upper limit.

PA.09	PID deviation limit	Default	0.00%
	Setting Range	0.00%~100.00%	

If the deviation between PID feedback and PID setting is smaller than the value of PA.09, PID control stops. The small deviation between PID feedback and PID setting will make the output frequency stabilize, effective for some closed-loop control applications.

PA.10	PID differential limit	Default	0.10%
	Setting Range	0.00%~100.00%	

It is used to set the PID differential output range. In PID control, the differential operation may easily cause system oscillation. Thus, the PID differential regulation is restricted to a small range.

PA.11	PID setting change time	Default	0.00s
	Setting Range	0.00s~650.00s	

The PID setting change time indicates the time required for PID setting changing from 0.0% to 100.0%. The PID setting changes linearly according to the change time, reducing the impact caused by sudden setting change on the system.

PA.12	PID feedback filter time	Default	0.00s
	Setting Range	0.00s~60.00s	

PA.13	PID output filter time	Default	0.00s
	Setting Range	0.00s~60.00s	

PA.12 is used to filter the PID feedback, helping to reduce interference on the feedback but slowing the response of the process closed-loop system.

PA.13 is used to filter the PID output frequency, helping to weaken sudden change of the AC drive output frequency but slowing the response of the process closed-loop system.

PA.15	Proportional gain Kp2	Default	20.0
	Setting Range	0.0~100.0	

PA.16	Integral time Ti2	Default	2.00s
	Setting Range	0.01s~10.00s	

PA.17	Differential time Td2	Default	0.00s
	Setting Range	0.00~10.000	

PA.18	PID parameter switchover condition	Default	0
	Setting Range	0	No switchover
		1	Switchover via X
2	Automatic switchover based on deviation		
PA.19	PID parameter switchover deviation 1	Default	20%
	Setting Range	0.0%~PA.20	
PA.20	PID parameter switchover deviation 2	Default	80%
	Setting Range	PA.19~100.0%	

In some applications, PID parameters switchover is required when one group of PID parameters cannot satisfy the requirement of the whole running process. These parameters are used for switchover between two groups of PID parameters.

Regulator parameters PA.15 to PA.17 are set in the same way as PA.05 to PA.07.

The switchover can be implemented either via a X terminal or automatically implemented based on the deviation.

If you select switchover via a X terminal, the X must be allocated with function 43 "PID parameter switchover". If the X is OFF, group 1 (PA.05 to PA.07) is selected. If the X is ON, group 2 (PA.15 to PA.17) is selected.

If you select automatic switchover, when the absolute value of the deviation between PID feedback and PID setting is smaller than the value of PA.19, group 1 is selected. When the absolute value of the deviation between PID feedback and PID setting is higher than the value of PA.20, group 2 is selected. When the deviation is between PA.19 and PA.20, the PID parameters are the linear interpolated value of the two groups of parameter values.

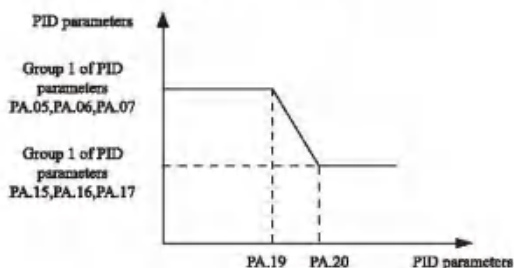

Figure 4-24 PID parameters switchover

PA.21	PID initial value		Default	0.0%
	Setting Range	0.0%~100.0%		
PA.22	PID initial value holding time		Default	0.00s
	Setting Range	0.00s~650.00s		

When the AC drive starts up, the PID starts closed-loop algorithm only after the PID output is fixed to the PID initial value (PA.21) and lasts the time set in PA.22.

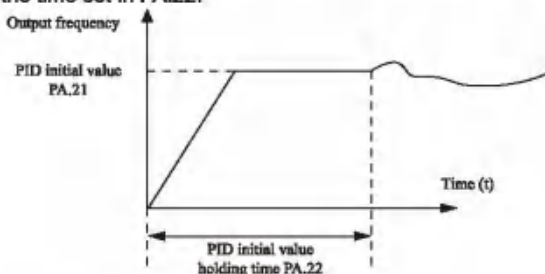

Figure 4-25 PID initial value function

PA.23	Maximum deviation between two PID outputs in forward direction		Default	1.00%
	Setting Range	0.00%~100.00%		
PA.24	Maximum deviation between two PID outputs in reverse direction		Default	1.00%
	Setting Range	0.00%~100.00%		

This function is used to limit the deviation between two PID outputs (2 ms per PID output) to suppress the rapid change of PID output and stabilize the running of the AC drive.

PA.23 and PA.24 respectively correspond to the maximum absolute value of the output deviation in forward direction and in reverse direction.

PA.25	PID integral property		Default	00
	Setting Range	Unit's digit	Integral separated	
		0	Invalid	
		1	Valid	
		Ten's digit	Whether to stop integral operation when the output reaches the limit	
		0	Continue integral operation	
1	Stop integral operation			

**Integral separated**

If it is set to valid, the PID integral operation stops when the X

allocated with function 38 "PID integral pause" is ON In this case, only proportional and differential operations take effect.

If it is set to invalid, integral separated remains invalid no matter whether the X allocated with function 38 "PID integral pause" is ON or not.

Whether to stop integral operation when the output reaches the limit.

If "Stop integral operation" is selected, the PID integral operation stops, which may help to reduce the PID overshoot.

PA.26	Detection value of PID feedback loss	Default	0.0%
	Setting Range	0.0%: Not judging feedback loss 0.1%: 100.0%	
PA.27	Detection time of PID feedback loss	Default	0.0s
	Setting Range	0.0s~20.0s	

These parameters are used to judge whether PID feedback is lost. If the PID feedback is smaller than the value of PA.26 and the lasting time exceeds the value of PA.27, the AC drive reports Err31 and acts according to the selected fault protection action.

PA.28	PID operation at stop	Default	0
	Setting Range	0	No PID operation at stop
		1	PID operation at stop

It is used to select whether to continue PID operation in the state of stop. Generally, the PID operation stops when the AC drive stops.

### Group Pb: Swing Frequency, Fixed Length and Count

The swing frequency function is applied to the textile and chemical fiber fields and the applications where traversing and winding functions are required.

The swing frequency function indicates that the output frequency of the AC drive swings up and down with the set frequency as the center. The trace of running frequency at the time axis is shown in the following figure.

The swing amplitude is set in Pb..00 and PB.01. When Pb.01 is set to 0, the swing amplitude is 0 and the swing frequency does not take effect.

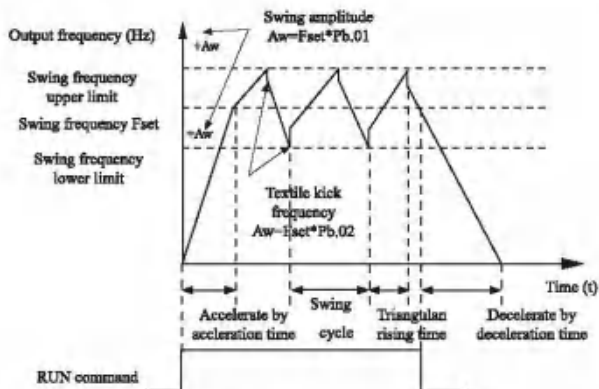

Figure 4-26 Swing frequency control

Pb.00	Swing frequency setting mode	Default	0
	Setting Range	0	Relative to the central frequency
		1	Relative to the maximum frequency

This parameter is used to select the base value of the swing amplitude.

0: Relative to the central frequency (P003 frequency source selection)

It is variable swing amplitude system. The swing amplitude varies with the central frequency (set frequency).

1: Relative to the maximum frequency (P012 maximum output frequency)

It is fixed swing amplitude system. The swing amplitude is fixed.

Pb.01	Swing frequency amplitude	Default	0.0%
	Setting Range	0.0%~100.0%	
Pb.02	Jump frequency amplitude	Default	0.0%
	Setting Range	0.0%~50.0%	

This parameter is used to determine the swing amplitude and jump frequency amplitude.

The swing frequency is limited by the frequency upper limit and frequency lower limit.

If relative to the central frequency (Pb.00 = 0), the actual swing amplitude AW is the calculation result of F0-07 (Frequency source selection) multiplied by Pb.01. If relative to the maximum frequency (Pb.00 = 1), the actual swing amplitude AW is the calculation result

of F0-10 (Maximum frequency) multiplied by Pb.01. Jump frequency = Swing amplitude AW x Pb.02 (Jump frequency amplitude). If relative to the central frequency (Pb.00 = 0), the jump frequency is a variable value. If relative to the maximum frequency (Pb.00 = 1), the jump frequency is a fixed value.

The swing frequency is limited by the frequency upper limit and frequency lower limit.

Pb.03	Swing frequency cycle	Default	10.0s
	Setting Range	0.1s~3000.0s	
Pb.04	Triangular wave rising time coefficient	Default	50.0%
	Setting Range	0.1%~100.0%	

Pb.03 specifies the time of a complete swing frequency cycle.

Pb.04 specifies the time percentage of triangular wave rising time to Pb.03 (Swing frequency cycle).

Triangular wave rising time = Pb.03 (Swing frequency cycle) x Pb.04 (Triangular wave rising time coefficient, unit: s)

Triangular wave falling time = Pb.03 (Swing frequency cycle) x (1 - Pb.04 Triangular wave rising time coefficient, unit: s)

Pb.05	Set length	Default	1000m
	Setting Range	0m~65535m	
Pb.06	Actual length	Default	0m
	Setting Range	0m~65535m	
Pb.07	Number of pulses per meter	Default	100.0
	Setting Range	0.1~6553.5	

The preceding parameters are used for fixed length control.

The length information is collected by X terminals. Pb.06 (Actual length) is calculated by dividing the number of pulses collected by the X terminal by Pb.07 (Number of pulses each meter).

When the actual length Pb.06 exceeds the set length in Pb.05, the YO terminal allocated with function 10 (Length reached) becomes ON.

During the fixed length control, the length reset operation can be performed via the X terminal allocated with function 28. For details, see the descriptions of P5.00 to P5.09.

Allocate corresponding X terminal with function 27 (Length count input) in applications. If the pulse frequency is high, X5 must be used.

Pb.08	Set count value	Default	1000
	Setting Range	1~65535	

Pb.09	Designated count value	Default	1000
	Setting Range	1~65535	

The count value needs to be collected by X terminal. Allocate the corresponding X terminal with function 25 (Counter input) in applications. If the pulse frequency is high, X5 must be used.

When the count value reaches the set count value (Pb.08), the YO terminal allocated with function 8 (Set count value reached) becomes ON. Then the counter stops counting.

When the counting value reaches the designated counting value (Pb.09), the YO terminal allocated with function 9 (Designated count value reached) becomes ON. Then the counter continues to count until the set count value is reached.

Pb.09 should be equal to or smaller than Pb.08.

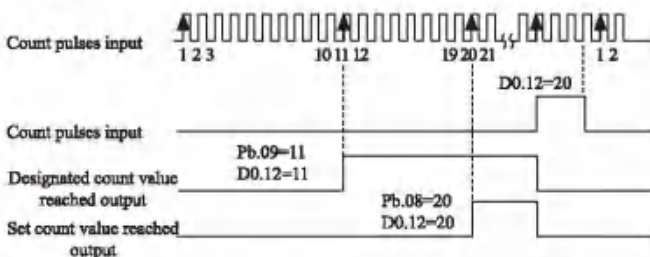

Figure 4-27 Reaching the set count value and designated count value

#### Group PC: Multi-Reference and Simple PLC Function

The Z8000 multi-reference has many functions. Besides multi-speed, it can be used as the setting source of the V/F separated voltage source and setting source of process PID. In addition, the multi-reference is relative value.

The simple PLC function is different from the Z8000 user programmable function. Simple PLC can only complete simple combination of multi-reference, while the user programmable function is more practical. For details, see the descriptions of group PC.

PC.00	Reference 0	Default	0.0%
	Setting Range	-100.0%~100.0%	
PC.01	Reference 1	Default	0.0%
	Setting Range	-100.0%~100.0%	
PC.02	Reference 2	Default	0.0%
	Setting Range	-100.0%~100.0%	

PC.03	Reference 3	Default	0.0%
	Setting Range	-100.0%~100.0%	
PC.04	Reference 4	Default	0.0%
	Setting Range	-100.0%~100.0%	
PC.05	Reference 5	Default	0.0%
	Setting Range	-100.0%~100.0%	
PC.06	Reference 6	Default	0.0%
	Setting Range	-100.0%~100.0%	
PC.07	Reference 7	Default	0.0%
	Setting Range	-100.0%~100.0%	
PC.08	Reference 8	Default	0.0%
	Setting Range	-100.0%~100.0%	
PC.09	Reference 9	Default	0.0%
	Setting Range	-100.0%~100.0%	
PC.10	Reference 10	Default	0.0%
	Setting Range	-100.0%~100.0%	
PC.11	Reference 11	Default	0.0%
	Setting Range	-100.0%~100.0%	
PC.12	Reference 12	Default	0.0%
	Setting Range	-100.0%~100.0%	
PC.13	Reference 13	Default	0.0%
	Setting Range	-100.0%~100.0%	
PC.14	Reference 14	Default	0.0%
	Setting Range	-100.0%~100.0%	
PC.15	Reference 15	Default	0.0%
	Setting Range	-100.0%~100.0%	

Multi-reference can be the setting source of frequency, V/F separated voltage and process PID. The multi-reference is relative value and ranges from -100.0% to 100.0%.

As frequency source, it is a percentage relative to the maximum frequency. As V/F separated voltage source, it is a percentage relative to the rated motor voltage.

As process PID setting source, it does not require conversion.

Multi-reference can be switched over based on different states of X terminals. For details, see the descriptions of group P5.

		Simple PLC running mode	Default	0
PC.16	Setting Range	0	Stop after the AC drive runs one cycle	
		1	Keep final values after the AC drive runs one cycle	
		2	Repeat after the AC drive runs one cycle	

0: Stop after the AC drive runs one cycle

The AC drive stops after running one cycle, and will not start up until receiving another command.

1: Keep final values after the AC drive runs one cycle

The AC drive keeps the final running frequency and direction after running one cycle.

2: Repeat after the AC drive runs one cycle

The AC drive automatically starts another cycle after running one cycle, and will not stop until receiving the stop command.

Simple PLC can be either the frequency source or V/F separated voltage source.

When simple PLC is used as the frequency source, whether parameter values of PC. 00 to PC. 15 are positive or negative determines the running direction. If the parameter values are negative, it indicates that the AC drive runs in reverse direction.

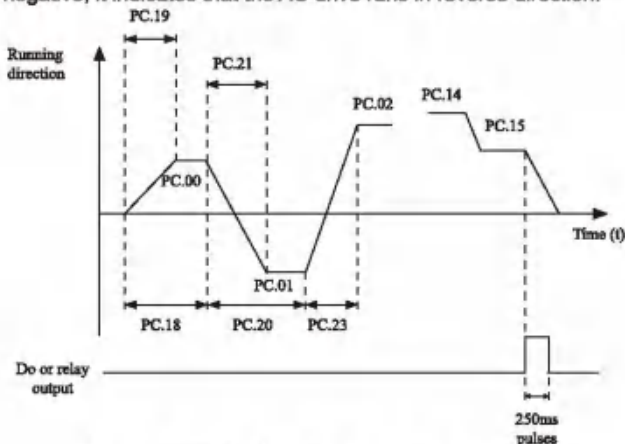

Figure 4-28 Simple PLC when used as frequency source

PC.17	Simple PLC retentive selection		Default	00
	Setting Range	Unit's digit	Retentive upon power failure	
0		No		
1		Yes		
Ten's digit		Retentive upon stop		
	0	No		
	1	Yes		

PLC retentive upon power failure indicates that the AC drive

memorizes the PLC running moment and running frequency before power failure and will continue to run from the memorized moment after it is powered on again. If the unit's digit is set to 0, the AC drive restarts the PLC process after it is powered on again.

PLC retentive upon stop indicates that the AC drive records the PLC running moment and running frequency upon stop and will continue to run from the recorded moment after it starts up again. If the ten's digit is set to 0, the AC drive restarts the PLC process after it starts up again.

PC.18	Running time of simple PLC reference 0	Default	0.0s (h)
	Setting Range	0.0s (h)~6553.5s (h)	
PC.19	Acceleration/deceleration time of simple PLC reference 0	Default	0
	Setting Range	0~3	
PC.20	Running time of simple PLC reference 1	Default	0.0s (h)
	Setting Range	0.0s (h) ~6553.5s (h)	
PC.21	Acceleration/deceleration time of simple PLC reference 1	Default	0
	Setting Range	0~3	
PC.22	Running time of simple PLC reference 2	Default	0.0s (h)
	Setting Range	0.0s (h) ~6553.5s (h)	
PC.23	Acceleration/deceleration time of simple PLC reference 2	Default	0
	Setting Range	0~3	
PC.24	Running time of simple PLC reference 3	Default	0.0s (h)
	Setting Range	0.0s (h) ~6553.5s (h)	
PC.25	Acceleration/deceleration time of simple PLC reference 3	Default	0
	Setting Range	0~3	
PC.26	Running time of simple PLC reference 4	Default	0.0s (h)
	Setting Range	0.0s (h) ~6553.5s (h)	
PC.27	Acceleration/deceleration time of simple PLC reference 4	Default	0
	Setting Range	0~3	

PC.28	Running time of simple PLC reference 5	Default	0.0s (h)
	Setting Range	0.0s (h) ~6553.5s (h)	
PC.29	Acceleration/deceleration time of simple PLC reference 5	Default	0
	Setting Range	0~3	
PC.30	Running time of simple PLC reference 6	Default	0.0s (h)
	Setting Range	0.0s (h) ~6553.5s (h)	
PC.31	Acceleration/deceleration time of simple PLC reference 6	Default	0
	Setting Range	0~3	
PC.32	Running time of simple PLC reference 7	Default	0.0s (h)
	Setting Range	0.0s (h) ~6553.5s (h)	
PC.33	Acceleration/deceleration time of simple PLC reference 7	Default	0
	Setting Range	0~3	
PC.34	Running time of simple PLC reference 8	Default	0.0s (h)
	Setting Range	0.0s (h) ~6553.5s (h)	
PC.35	Acceleration/deceleration time of simple PLC reference 8	Default	0
	Setting Range	0~3	
PC.36	Running time of simple PLC reference 9	Default	0.0s (h)
	Setting Range	0.0s (h) ~6500.0s (h)	
PC.37	Acceleration/deceleration time of simple PLC reference 9	Default	0
	Setting Range	0~3	
PC.38	Running time of simple PLC reference 10	Default	0.0s (h)
	Setting Range	0.0s (h) ~6500.0s (h)	
PC.39	Acceleration/deceleration time of simple PLC reference 10	Default	0
	Setting Range	0~3	
PC.40	Running time of simple PLC reference 11	Default	0.0s (h)
	Setting Range	0.0s (h) ~6500.0s (h)	

PC.41	Acceleration/deceleration time of simple PLC reference 11	Default	0
	Setting Range	0~3	
PC.42	Running time of simple PLC reference 12	Default	0.0s (h )
	Setting Range	0.0s (h ) ~6500.0s (h )	
PC.43	Acceleration/deceleration time of simple PLC reference 12	Default	0
	Setting Range	0~3	
PC.44	Running time of simple PLC reference 13	Default	0.0s (h )
	Setting Range	0.0s (h ) ~6500.0s (h )	
PC.45	Acceleration/deceleration time of simple PLC	Default	0
	Setting Range	0~3	
PC.46	Running time of simple PLC reference 14	Default	0.0s (h )
	Setting Range	0.0s (h ) ~6500.0s (h )	
PC.47	Acceleration/deceleration time of simple PLC	Default	0
	Setting Range	0~3	
PC.48	Running time of simple PLC reference 15	Default	0.0s (h )
	Setting Range	0.0s (h ) ~6500.0s (h )	
PC.49	Acceleration/deceleration time of simple PLC reference 15	Default	0
	Setting Range	0~3	
PC.50	Time unit of simple PLC	Default	0
	Setting Range	0	S (second)
		1	h (hour)
PC.51	Reference 0 source	Default	0
	Setting Range	0	Set by PC.00
		1	FIV
		2	FIC
		3	FIA
		4	PULSE setting
		5	PID
6	Set by preset frequency (P010), modified via terminal UP/DOWN		

It determines the setting channel of reference 0. You can perform convenient switchover between the setting channels. When multi-reference or simple PLC is used as frequency source, the switchover between two frequency sources can be realized easily.

### Group PD: Communication Parameters

Please refer to the "Z8000 communication protocol"

### Group PP: User-Defined Function Codes

PP.00	User password	Default	0
	Setting Range	0~65535	

If it is set to any non-zero number, the password protection function is enabled. After a password has been set and taken effect, you must enter the correct password in order to enter the menu. If the entered password is incorrect you cannot view or modify parameters.

If PP.00 is set to 00000, the previously set user password is cleared, and the password protection function is disabled.

PP.01	Restore default settings	Default	0
	Setting Range	0	No operation
		1	Restore factory settings except motor parameters
		2	Clear records
		4	Restore user backup parameters
501	Back up current user parameters		

#### 1: Restore default settings except motor parameters

If PP.01 is set to 1, most function codes are restored to the default settings except motor parameters, frequency reference resolution (P0.22, fault records, accumulative running time (P7.09), accumulative power-on time (P7.13) and accumulative power consumption (P7.14).

#### 2: Clear records

If PP.01 is set to 2, the fault records, accumulative running time (P7.09), accumulative power-on time (P7.13) and accumulative power consumption (P7.14) are cleared.

#### 501: Back up current user parameters

If PP.01 is set to 501, the current parameter settings are backed up, helping you to restore the setting if incorrect parameter setting is performed.

#### 4: Restore user backup parameters

If PP.01 is set to 4, the previous backup user parameters are restored.

**Group C0: Torque Control and Restricting Parameters**

C0.00	Speed/Torque control selection	Default	0
	Setting Range	0	Speed control
1		Torque control	

It is used to select the AC drive's control mode: speed control or torque control.

The Z8000 provides X terminals with two torque related functions, function 29 (Torque control prohibited) and function 46 (Speed control/Torque control switchover). The two X terminals need to be used together with C0.00 to implement speed control/torque control switchover.

If the X terminal allocated with function 46 (Speed control/Torque control switchover) is OFF, the control mode is determined by C0.00. If the X terminal allocated with function 46 is ON, the control mode is reverse to the value of C0.00.

However, if the X terminal with function 29 (Torque control prohibited) is ON, the AC drive is fixed to run in the speed control mode.

C0.01	Torque setting source in torque control	Default	0
	Setting Range	0	Digital setting (C0.03)
		1	FIV
		2	FIC
		3	Reserved
		4	PULSE setting
		5	Communication setting
		6	MIN (FIV,FIC)
7	MAX (FIV,FIC)		
C0.03	Torque digital setting in torque control	Default	150%
	Setting Range	-200.0%~200.0%	

C0.01 is used to set the torque setting source. There are a total of eight torque setting sources. The torque setting is a relative value. 100.0% corresponds to the AC drive's rated torque. The setting range is -200.0% to 200.0%, indicating the AC drive's maximum torque is twice of the AC drive's rated torque.

When the torque setting using 1 ~ 7, communication, analog input and pulse input. The data format is -100.00% to 100.00%. 100% corresponds to the value of C0.03.

C0.05	Forward maximum frequency in torque control	Default	50.00Hz
	Setting Range	0.00Hz~maximum frequency	
C0.06	Reverse maximum frequency in torque control	Default	50.00Hz
	Setting Range	0.00Hz~maximum frequency	

This two parameters are used to set the maximum frequency in forward or reverse rotation in torque control mode.

In torque control, if the load torque is smaller than the motor output torque, the motor's rotational speed will rise continuously. To avoid runaway of the mechanical system, the motor maximum rotating speed must be limited in torque control.

You can implement continuous change of the maximum frequency in torque control dynamically by controlling the frequency upper limit.

C0.07	Acceleration time in torque control	Default	0.00s
	Setting Range	0.00s~650.00s	
C0.08	Deceleration time in torque control	Default	0.00s
	Setting Range	0.00s~650.00s	

In torque control, the difference between the motor output torque and the load torque determines the speed change rate of the motor and load. The motor rotational speed may change quickly and this will result in noise or too large mechanical stress. The setting of acceleration/deceleration time in torque control makes the motor rotational speed change softly.

However, in applications requiring rapid torque response, set the acceleration/deceleration time in torque control to 0.00s. For example, two AC drives are connected to drive the same load. To balance the load allocation, set one AC drive as master in speed control and the other as slave in torque control. The slave receives the master's output torque as the torque command and must follow the master rapidly. In this case, the acceleration/deceleration time of the slave in torque control is set to 0.0s.

### Group C5: Control Optimization Parameters

C5.00	PWM switchover frequency upper limit	Default	12.00Hz
	Setting Range	0.00Hz~15Hz	

This parameter is valid only for V/F control.

It is used to determine the wave modulation mode in V/F control of

asynchronous motor.

If the frequency is lower than the value of this parameter, the waveform is 7-segment continuous modulation. If the frequency is higher than the value of this parameter, the waveform is 5-segment intermittent modulation.

The 7-segment continuous modulation causes more loss to switches of the AC drive but smaller current ripple. The 5-segment intermittent modulation causes less loss to switches of the AC drive but larger current ripple. This may lead to motor running instability at high frequency. Do not modify this parameter generally.

For instability of V/F control, refer to parameter P4.11. For loss to AC drive and temperature rise, refer to parameter P017.

C5.01	PWM modulation mode		Default	0
	Setting Range	0	0: Asynchronous modulation	
1		1: Synchronous modulation		
C5.02	Dead zone compensation mode selection		Default	1
	Setting Range	0	0: No compensation	
		1	1: Compensation mode 1	
2		2: Compensation mode 2		
C5.03	Random PWM depth		Default	0
	Setting Range	0	0: Random PWM invalid	
1		1~10		
C5.04	Rapid current limit		Default	1
	Setting Range	0	0: Disabled	
1		1: Enabled		
C5.05	Current detection compensation		Default	5
	Setting Range	0~100		
C5.06	Undervoltage threshold		Default	100%
	Setting Range	60.0~140.0%		
C5.07	SFVC optimization mode selection		Default	1
	Setting Range	0	No optimization	
		1	Optimization mode 1	
2		Optimization mode 2		

1: Optimization mode 1

It is used when the requirement on torque control linearity is high.

2: Optimization mode 2

It is used for the requirement on speed stability is high.

### Group C6: FI Curve Setting(FI is FIV or FIC)

C6.00	FI curve 4 minimum input	Default	0.00V
	Setting Range	0.00V~C6.02	
C6.01	Corresponding setting of FI curve 4 minimum input	Default	0.0%
	Setting Range	-100.0%~100.0%	
C6.02	FI curve 4 inflexion 1 input	Default	3.00V
	Setting Range	C6.00~C6.04	
C6.03	Corresponding setting of FI curve 4 inflexion 1 input	Default	30.0%
	Setting Range	-100.0%~100.0%	
C6.04	FI curve 4 inflexion 2 input	Default	6.00V
	Setting Range	C6.02~C6.06	
C6.05	Corresponding setting of FI curve 4 inflexion 2 input	Default	60.0%
	Setting Range	-100.0%~100.0%	
C6.06	FI curve 4 maximum input	Default	10.00V
	Setting Range	C6.06~10.00V	
C6.07	Corresponding setting of FI curve 4 maximum input	Default	100.0%
	Setting Range	-100.0%~100.0%	
C6.08	FI curve 5 minimum input	Default	0.00V
	Setting Range	0.00V~C6.10	
C6.09	Corresponding setting of FI curve 5 minimum input	Default	0.0%
	Setting Range	-100.0%~100.0%	
C6.10	FI curve 5 inflexion 1 input	Default	3.00V
	Setting Range	C6.08~C6.12	
C6.11	Corresponding setting of FI curve 5 inflexion 1 input	Default	30.0%
	Setting Range	-100.0%~100.0%	
C6.12	FI curve 5 inflexion 2 input	Default	6.00V
	Setting Range	C6.10~C6.14	
C6.13	Corresponding setting of FI curve 5 inflexion 2 input	Default	60.0%
	Setting Range	-100.0%~100.0%	
C6.14	FI curve 5 maximum input	Default	10.00V
	Setting Range	C6.12~10.00V	
C6.15	Corresponding setting of FI curve 5 maximum input	Default	100.0%
	Setting Range	-100.0%~100.0%	

The function of curve 4 and curve 5 is similar to that curve 1 to curve 3, but curve 1 to curve 3 are lines, and curve 4 and curve 5 are 4-point curves, implementing more flexible corresponding relationship. The schematic diagram of curve 4 and curve 5 is shown in the following figure.

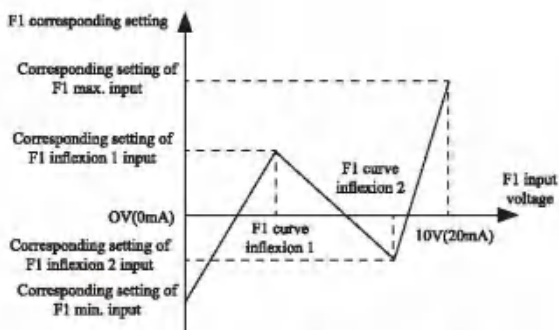

Figure 4-29 Schematic diagram curve 4 and curve 5

When setting curve 4 and curve 5, note that the curve's minimum input voltage, inflexion 1 voltage, inflexion 2 voltage and maximum voltage must be in increment order.

P5.33 (F1 curve selection) is used to select curve for FIV to FIC.

C6.16	Jump point of FIV Input corresponding setting	Default	0.0%
	Setting Range	-100.0%~100.0%	
C6.17	Jump amplitude of FIV input corresponding setting	Default	0.5%
	Setting Range	0.0%~100.0%	
C6.18	Jump point of FIC input corresponding setting	Default	0.0%
	Setting Range	-100.0%~100.0%	
C6.19	Jump amplitude of FIC input corresponding setting	Default	0.5%
	Setting Range	0.0%~100.0%	

The FI terminals (FIV to FIC) of the Z8000 all support the corresponding setting jump function, which fixes the FI input corresponding setting at the jump point when FI input corresponding setting jumps around the jump range.

For example, FIV input voltage jumps around 5.00 V and the jump range is 4.90–5.10V.FIV minimum input 0.00 V corresponds to 0.0%

and maximum input 10.00 V corresponds to 100.0%. The detected FIV input corresponding setting varies between 49.0% and 51.0%. If you set C6.16 to 50.0% and C6.17 to 1.0%, then the obtained FIV input corresponding setting is fixed to 50.0%, eliminating the fluctuation effect.

### Group CC: FI/FO Correction

CC.00	FIV measured voltage 1	Default	Factory-corrected
	Setting Range	0.500V~4.000V	
CC.01	FIV displayed voltage 1	Default	Factory-corrected
	Setting Range	0.500V~4.000V	
CC.02	FIV measured voltage 2	Default	Factory-corrected
	Setting Range	6.000V~9.999V	
CC.03	FIV displayed voltage 2	Default	Factory-corrected
	Setting Range	6.000V~9.999V	
CC.04	FIC measured voltage 1	Default	Factory-corrected
	Setting Range	0.500V~4.000V	
CC.05	FIC displayed voltage 1	Default	Factory-corrected
	Setting Range	0.500V~4.000V	
CC.06	FIC measured voltage 2	Default	Factory-corrected
	Setting Range	6.000V~9.999V	
CC.07	FIC displayed voltage 2	Default	Factory-corrected
	Setting Range	-9.999V~10.000V	

These parameters are used to correct the FI to eliminate the impact of FI zero offset and gain.

They have been corrected upon delivery. When you resume the factory values, these parameters will be restored to the factory-corrected values. Generally, you need not perform correction in the applications.

Measured voltage indicates the actual output voltage value measured by instruments such as the multimeter. Displayed voltage indicates the voltage display value sampled by the AC drive. For details, refer to D0.21, D0.22. During correction, send two voltage values to each FI terminal, and save the measured values and displayed values to the function codes CC.00 to CC.07. Then the AC drive will automatically perform FI zero offset and gain correction.

CC.12	FOV target voltage 1	Default	Factory-corrected
	Setting Range	0.500V~4.000V	
CC.13	FOV measured voltage 1	Default	Factory-corrected
	Setting Range	0.500V~4.000V	
CC.14	FOV target voltage 2	Default	Factory-corrected
	Setting Range	6.000V~9.999V	

CC.15	FOV measured voltage 2	Default	Factory-corrected
	Setting Range	6.000V~9.999V	
CC.16	FOV target voltage 1	Default	Factory-corrected
	Setting Range	0.500V~4.000V	
CC.17	FOV measured voltage 1	Default	Factory-corrected
	Setting Range	0.500V~4.000V	
CC.18	FOV target voltage 2	Default	Factory-corrected
	Setting Range	6.000V~9.999V	
CC.19	FOV measured voltage 2	Default	Factory-corrected
	Setting Range	6.000V~9.999V	

These parameters are used to correct the FOV/FOC.

They have been corrected upon delivery. When you resume the factory values, these parameters will be restored to the factory-corrected values. You need not perform correction in the applications.

Target voltage indicates the theoretical output voltage of the AC drive. Measured voltage indicates the actual output voltage value measured by instruments such as the multimeter.

### Group D0: Monitoring Parameters

Group D0 is used to monitor the AC drive's running state. You can view the parameter values by using operation panel, convenient for on-site commissioning, or from the host computer by means of communication .

D0.00 to D0.31 are the monitoring parameters in the running and stop state defined by P7.03 and P7.04.

For more details, see Table 6-1

Function Code	Parameter Name	Unit
D0.00	Running frequency (Hz )	0.01Hz
D0.01	Set frequency (Hz )	0.01Hz
D0.02	Bus voltage (V )	0.1V
D0.03	Output voltage (V )	1V
D0.04	Output current (A )	0.01A
D0.05	Output power (kW )	0.1kW
D0.06	Output torque ( % )	0.1%
D0.07	X input state	1
D0.08	YO output state	1
D0.09	FIV voltage (V )	0.01V
D0.10	FIC voltage (V )	0.01V
D0.11	reserved	

Function Code	Parameter Name	Unit
D0.12	Count value	1
D0.13	Length	1
D0.14	Load speed	1
D0.15	PID setting	1
D0.16	PID feedback	1
D0.17	PLCstage	1
D0.18	Input pulse frequency	0.01kHz
D0.19	Feedback speed	0.1Hz
D0.20	Remaining running time	0.1Min
D0.21	FIV voltage before correction	0.001V
D0.22	FIC voltage before correction	0.001V
D0.23	reserved	
D0.24	Linear speed	1m/Min
D0.25	On the current time	1Min
D0.26	The current running time	0.1Min
D0.27	Pulse input frequency	1Hz
D0.28	Communication setting value	0.01%
D0.29	Encoder feedback speed	0.01Hz
D0.30	Main frequency X	0.01Hz
D0.31	Auxiliary frequency Y	0.01Hz
D0.32	View any memory address values	1
D0.33	Synchronous motor rotor position	0.0°
D0.34		1
D0.35	Target torque	0.1%
D0.36	Resolver position	1
D0.37	Power factor angle	0.1
D0.38	ABZ position	0.0
D0.39	Target voltage upon V/F separation	1V
D0.40	Output voltage upon V/F separation	1V
D0.41	X state visual display	1
D0.42	YO state visual display	1
D0.43	X function state visual display 1	1
D0.44	X function state visual display 2	1
D0.45	Current fault code	0

## Chapter 5

### Fault checking and ruled out

#### 5-1 Fault alarm and countermeasures

Z8000 inverter with a total of 31 warning information and the protection function, once the failure, protection function, frequency converter to stop output, frequency converter fault relay contact action, and in the frequency converter fault code shown on the display panel. Users before seeking service, can according to this section first prompt checking, analysis the cause of the problem, find out the solution. If belong to the dotted line frame stated reason, please seek service, with you purchased inverter agents or direct contact with our company.

warning information OUOC overcurrent or overvoltage signals for hardware, in most cases the hardware overvoltage fault cause OUOC alarm.

Fault Name	Display	Possible Causes	Solutions
Inverter unit protection	OC	1: The output circuit is grounded or short circuited. 2: The connecting cable of the motor is too long. 3: The module overheats. 4: The internal connections become loose. 5: The main control board is faulty. 6: The drive board is faulty. 7: The inverter module is faulty	1: Eliminate external faults. 2: Install a reactor or an output filter. 3: Check the air filter and the cooling fan. 4: Connect all cables Properly. 5, 6, 7: Looking for technical support

Fault Name	Display	Possible Causes	Solutions
Overcurrent during acceleration	OC1	1: The output circuit is grounded or short circuited. 2: Motor auto-tuning is not Performed. 3: The acceleration time is too Short. 4: Manual torque boost or V/F curve is not appropriate. 5: The voltage is too low. 6: The startup operation is performed on the rotating motor. 7: A sudden load is added during Acceleration. 8: The AC drive model is of too small power class.	1: Eliminate external faults. 2: Perform the motor auto-tuning. 3: Increase the acceleration time. 4: Adjust the manual torque boost or V/F curve. 5: Adjust the voltage to normal range. 6: Select rotational speed tracking restart or start the motor after it stops. 7: Remove the added load. 8: Select an AC drive of higher power class.
Overcurrent during deceleration	OC2	1: The output circuit is grounded or short circuited. 2: Motor auto-tuning is not performed. 3: The deceleration time is too Short. 4: The voltage is too low. 5: A sudden load is added during Deceleration. 6: The braking unit and braking resistor are not installed.	1: Eliminate external faults. 2: Perform the motor auto-tuning. 3: Increase the deceleration time. 4: Adjust the voltage to normal range. 5: Remove the added load. 6: Install the braking unit and braking resistor.
Overcurrent at constant speed	OC3	1: The output circuit is grounded or short circuited. 2: Motor auto-tuning is not performed. 3: The voltage is too low. 4: A sudden load is added during operation. 5: The AC drive model is of too small power class.	1: Eliminate external faults. 2: Perform the motor auto-tuning. 3: Adjust the voltage to normal range. 4: Remove the added load. 5: Select an AC drive of higher power class.

Fault Name	Display	Possible Causes	Solutions
Overvoltage during acceleration	OU1	1: The input voltage is too high. 2: An external force drives the motor during acceleration. 3: The acceleration time is too Short. 4: The braking unit and braking resistor are not installed.	1: Adjust the voltage to normal range. 2: Cancel the external force or install a braking resistor. 3: Increase the acceleration time. 4: Install the braking unit and braking resistor.
Overvoltage during deceleration	OU2	1: The input voltage is too high. 2: An external force drives the motor during deceleration. 3: The deceleration time is too Short. 4: The braking unit and braking resistor are not installed.	1: Adjust the voltage to normal range. 2: Cancel the external force or install the braking resistor. 4: Install the braking unit and braking resistor.
Overvoltage at constant speed	OU3	1: The input voltage is too high. 2: An external force drives the motor during deceleration.	1: Adjust the voltage to normal range. 2: Cancel the external force or install the braking resistor.
Control power supply fault	POFF	1: The input voltage is too high. 2: An external force drives the motor during deceleration.	1: Adjust the voltage to normal range. 2: Cancel the external force or install the braking resistor.
Undervoltage	LU	1: Instantaneous power failure occurs on the input power supply. 2: The AC drive's input voltage is not within the allowable range. 3: The bus voltage is abnormal. 4: The rectifier bridge and buffer resistor are faulty. 5: The drive board is faulty. 6: The main control board is faulty.	1: Reset the fault. 2: Adjust the voltage to normal range. 3, 4, 5, 6: Looking for technical support.

Fault Name	Display	Possible Causes	Solutions
AC drive overload	OL2	1: The load is too heavy or locked-rotor occurs on the motor. 2: The AC drive model is of too small power class.	1: Reduce the load and check the motor and mechanical condition. 2: Select an AC drive of higher power class
Motor overload	OL1	1: P9.01 is set improperly. 2: The load is too heavy or locked- rotor occurs on the motor. 3: The AC drive model is of too small power class.	1: Set P9.01 correctly. 2: Reduce the load and check the motor and the mechanical condition. 3: Select an AC drive of higher power class.
Power input phase loss	LI	1: The three-phase power input is abnormal. 2: The drive board is faulty. 3: The lightning board is faulty. 4: The main control board is faulty.	1: Eliminate external faults. 2, 3, 4: Looking for technical support
Power output phase loss	Lo	1: The cable connecting the AC drive and the motor is faulty. 2: The AC drive's three-phase outputs are unbalanced when the motor is running. 3: The drive board is faulty. 4: The module is faulty.	1: Eliminate external faults. 2: Check whether the motor three-phase winding is normal. 3: Looking for technical support .
Module overheat	OH	1: The ambient temperature is too temperature. 2: The air filter is blocked. 3: The fan is damaged. 4: The thermally sensitive resistor of the module is damaged. 5: The inverter module is damaged.	1: Lower the ambient High. 2: Clean the air filter. 3: Replace the damaged fan 4: Replace the damaged thermally sensitive resistor. 5: Replace the inverter module.
External equipment fault	EF	1: External fault signal is input via X. 2: External fault signal is input via virtual I/O.	Reset the operation.

Fault Name	Display	Possible Causes	Solutions
Communication fault	CE	1: The host computer is in abnormal state. 2: The communication cable is faulty. 3: P028 is set improperly. 4: The communication parameters in group PD are set improperly.	1: Check the cabling of host computer. 2: Check the communication cabling. 3: Set P028 correctly. 4: Set the communication parameters properly.
Contactor fault	rAy	1: The drive board and power supply are faulty. 2: The contactor is faulty.	1: Replace the faulty drive board or power supply board. 2: Replace the faulty Contactor.
Current detection fault	IE	1: The HALL device is faulty. 2: The drive board is faulty.	1: Replace the faulty HALL device. 2: Replace the faulty drive board.
Motor auto-tuning fault	TE	1: The motor parameters are not set according to the nameplate. 2: The motor auto-tuning times out.	1: Set the motor parameters according to the nameplate properly. 2: Check the cable connecting the AC drive and the motor.
Encoder fault	PG	1: The encoder type is incorrect. 2: The cable connection of the encoder is incorrect. 3: The encoder is damaged. 4: The PG card is faulty.	1: Set the encoder type correctly based on the actual situation. 2: Eliminate external faults. 3: Replace the damaged Encoder. 4: Replace the faulty PG card.
EEPROM read-write fault	EEP	The EEPROM chip is damaged.	Replace the main control board.
AC drive hardware fault	OUOC	1: Overvoltage exists. 2: Overcurrent exists.	1: Handle based on Overvoltage. 2: Handle based on overcurrent.
Short circuit to ground	GND	The motor is short circuited to the ground.	Replace the cable or motor.
Accumulative running time reached	END1	The accumulative running time reaches the setting value.	Clear the record through The parameter initialization function.

Fault Name	Display	Possible Causes	Solutions
Accumulative power-on time reached	END2	The accumulative power-on time reaches the setting value.	Clear the record through The parameter initialization function.
Load becoming 0	LOAD	The AC drive running current is lower than P9.64.	Check that the load is disconnected or the setting of P9.64 and P9.65 is correct.
PID feedback lost during running	PIDE	The PID feedback is lower than the setting of PA.26.	Check the PID feedback signal or set PA.26 to a proper value.
Pulse-by-pulse current limit fault	CBC	1: The load is too heavy or locked-rotor occurs on the motor. 2: The AC drive model is of too small power class.	1: Reduce the load and check the motor and mechanical condition. 2: Select an AC drive of higher power class.
Too large speed deviation	ESP	1: The encoder parameters are set incorrectly. 2: The motor auto-tuning is not Performed. 3: P9.69 and P9.70 are set incorrectly.	1: Set the encoder parameters properly. 2: Perform the motor auto-tuning. 3: Set P9.69 and P9.70 correctly based on the actual situation.
Motor over-speed	oSP	1: The encoder parameters are set incorrectly. 2: The motor auto-tuning is not Performed. 3: P9.69 and P9.70 are set incorrectly.	1: Set the encoder parameters properly. 2: Perform the motor auto-tuning. 3: Set P9.69 and P9.70 correctly based on the actual situation.
Initial position fault	ini	The motor parameters are not set based on the actual situation.	Check that the motor parameters are set correctly and whether the setting of rated current is too small.

## 5.2 Common Faults and Solutions

You may come across the following faults during the use of the AC drive. Refer to the following table for simple fault analysis.

Table 5-1 Troubleshooting to common faults of the AC drive

SN	Fault	Possible Causes	Solutions
1	There is no display at power-on.	<p>1: There is no power supply to the AC drive or the power input to the AC drive is too low.</p> <p>2: The power supply of the switch on the drive board of the AC drive is Faulty.</p> <p>3: The rectifier bridge is damaged.</p> <p>4: The control board or the operation panel is faulty.</p> <p>5: The cable connecting the control board and the drive board and the operation panel breaks.</p>	<p>1: Check the power supply.</p> <p>2: Check the bus voltage.</p> <p>3: Looking for technical support</p>
2	"8000" is displayed at power-on.	<p>1: The cable between the drive board and the control board is in poor contact.</p> <p>2: Related components on the control board are damaged.</p> <p>3: The motor or the motor cable is short circuited to the ground.</p> <p>4: The HALL device is faulty.</p> <p>5: The power input to the AC drive is too low.</p>	Looking for technical support
3	"GND" is displayed at power-on.	<p>1: The motor or the motor output cable is short-circuited to the ground.</p> <p>2: The AC drive is damaged.</p>	<p>1: Measure the insulation of the motor and the output cable with a megger.</p> <p>2: Looking for technical support</p>
4	The AC drive display is normal upon power-on. But "8000" is displayed after running and stops immediately.	<p>1: The cooling fan is damaged or locked-rotor occurs.</p> <p>2: The external control terminal cable is short circuited.</p>	<p>1: Replace the damaged fan.</p> <p>2: Eliminate external fault.</p>

SN	Fault	Possible Causes	Solutions
5	OH (module overheat) fault is reported frequently.	1: The setting of carrier frequency is too high. 2: The cooling fan is damaged, or the air filter is blocked. 3: Components inside the AC drive are damaged (thermal coupler or others).	1: Reduce the carrier frequency (P017). 2: Replace the fan and clean the air filter. 3: Looking for technical support
6	The motor does not rotate after the AC drive runs.	1: Check the motor and the motor Cables. 2: The AC drive parameters are set improperly (motor parameters). 3: The cable between the drive board and the control board is in poor contact. 4: The drive board is faulty.	1: Ensure the cable between the AC drive and the motor is normal. 2: Replace the motor or clear mechanical faults. 3: Check and re-set motor parameters.
7	The X terminals are disabled.	1: The parameters are set incorrectly. 2: The external signal is incorrect 3: The jumper bar across OP and +24 V becomes loose. 4: The control board is faulty.	1: Check and reset the parameters in group P5. 2: Re-connect the external signal cables. 3: Re-confirm the jumper bar across OP and +24 V. 4: Looking for technical support
8	The motor speed is always low in CLVC mode.	1: The encoder is faulty. 2: The encoder cable is connected incorrectly or in poor contact. 3: The PG card is faulty. 4: The drive board is faulty.	1: Replace the encoder and ensure the cabling is proper. 2: Replace the PG card. 3: Looking for technical support
9	The AC drive reports overcurrent and overvoltage frequently.	1: The motor parameters are set improperly. 2: The acceleration/ deceleration time is improper. 3: The load fluctuates.	1: Re - set motor parameters or re-perform the motor auto-tuning. 2: Set proper acceleration/ deceleration time. 3: Looking for technical support
10	rAy is reported upon power-on or running.	The soft startup contactor is not picked up.	1: Check whether the contactor cable is loose. 2: Check whether the contactor is faulty. 3: Check whether 24 V power supply of the contactor is faulty. 4: Looking for technical support

## Chapter 6 Maintenance



### WARNING

- Maintenance must be performed according to designated maintenance methods.
- Maintenance, inspection and replacement of parts must be performed only by certified person.
- After turning off the main circuit power supply, wait for 10 minutes before maintenance or inspection.
- DO NOT directly touch components or devices of PCB board. Otherwise inverter can be damaged by electrostatic.
- After maintenance, all screws must be tightened.

### 6.1 Inspection

In order to prevent the fault of inverter to make it operate smoothly in high-performance for a long time, user must inspect the inverter periodically (within half year). The following table indicates the inspection content.

Items to be checked	Main inspections		Criteria
	Inspection content	Frequency	Means/Methods
Operation environment	1. temperature 2. humidity 3. visual 4. vapor 5. gases	1. Point thermometer hygrometer 2. observation 3. Visual Examination and smelling	1. ambient temperature shall be lower than 40°C , otherwise, the rated values should be decreased. Humidity shall meet the requirement 2. no dust accumulation, no traces of water leakage and no condensate. 3. no abnormal color and smell.
Inverter	1. vibration 2. cooling and heating 3. noise	1. Point thermometer 2. Comprehensive observation 3. listening	1. smooth operation without vibration 2. fan is working in good condition. Speed and air flow are normal. No abnormal heat.

Items to be checked	Main inspections		Criteria
	Inspection content	Frequency	Means/Methods
Motor	1. vibration 2. heat 3. noise	1. Comprehensive observation 2. Point thermometer 3. listening	1. No abnormal vibration and no abnormal noise. 2. No abnormal heat. 3. No abnormal noise
Operation status parameters	1. power input voltage 2. inverter output voltage 3. inverter output current 4. Internal temperature	1. voltmeter 2. Rectifying voltmeter 3. ammeter 4. Point thermometer	1. satisfying the specification 2. satisfying the specification 3. satisfying the Specification 4. temperature rise is lower than 40°C

## 6.2 Periodic Maintenance

Customer should check the drive every 3 months or 6 months according to the actual environment.

6.2.1 Check whether the screws of control terminals are loose. If so, tighten them with a screwdriver;

6.2.2 Check whether the main circuit terminals are properly connected; whether the mains cables are over heated;

6.2.3 Check whether the power cables and control cables are damaged, check especially for any wear on the cable tube;

6.2.4 Check whether the insulating tapes around the cable lugs are stripped;

6.2.5 Clean the dust on PCBs and air ducts with a vacuum cleaner;

6.2.6 For drives that have been stored for a long time, it must be powered on every 2 years. When supplying AC power to the drive, use a voltage regulator to raise the input voltage to rated input voltage gradually. The drive should be powered for 5 hours without load.

6.2.7 Before performing insulation tests, all main circuit input/output terminals should be short-circuited with conductors. Then proceed insulation test to the ground. Insulation test of single main circuit terminal to ground is forbidden; otherwise the drive might be damaged. Please use a 500V Mega-Ohm-Meter.

6.2.8 Before the insulation test of the motor, disconnect the motor from the drive to avoid damaging it.

6.3 Replacement of wearing parts

Fans and electrolytic capacitors are wearing part, please make

periodic replacement to ensure long term, safety and failure-free operation. The replacement periods are as follows:

- ◆ Fan: Must be replaced when using up to 20,000 hours;
- ◆ Electrolytic Capacitor: Must be replaced when using up to 30,000~40, 000 hours.

## Chapter 7

# Peripheral Devices Selection

Check the motor capacity of the inverter you purchased. Appropriate peripheral devices must be selected according to the capacity. Refer to the following list and prepare appropriate peripheral devices:

### 7-1 Peripheral Devices Description

Peripheral Devices Name	Description
Moulded case circuit break (MCCB) or earth leakage circuit break (ELB), fuse	The breaker must be selected carefully since an In-rush current flows in the inverter at power on.
Magnetic contactor (MC)	Install the MC to ensure safety. Do not use this MC to start and stop the inverter. Doing so will cause the inverter life to be shorten.
AC/DC Reactor	Reactor (option) should be used when power harmonics measures are taken, the power factor is to be improved or the inverter is installed near a large power supply system (1000KVA or more). The inverter may be damaged if you do not use reactors. Select the reactor according to the model. For the 160KW or less, remove the jumpers across terminals P/+---<-> to connect to the DC reactor. For the 250KW or more, a DC reactor is supplied. Please always install the reactor.
Noise filter	Install a noise filter to reduce the electromagnetic noise generated from the inverter. Effective in the range from about 1MHz to 10MHz. When more wires are passed through, a more effective result can be obtained.
Brake resistor and brake unit	To improve the brake capability at deceleration.
Ferrite ring	To reduce the disturbance which is generated by inverter

## 7-2 Applied DC reactor Specification

Applicable Inverter Type	Motor Output (kW)	DC Reactor Selection	
		Rated currenacy (A)	Inductance value (mH)
Z8200-0R4G	0.4	3	28
Z8200-0R7G	0.75	3	28
Z8200-1R5G	1.5	6	11
Z8200-2R2G	2.2	6	11
Z8200-3R7G	3.7	23	3.6
Z8400-0R4G	0.4	6	11
Z8400-0R7G	0.75	6	11
Z8400-1R5G	1.5	6	11
Z8400-2R2G	2.2	6	11
Z8400-3R7G/5R5P	3.7/5.5	12	6.3
Z8400-5R5G/7R5P	5.5/7.5	23	3.6
Z8400-7R5G/11P	7.5/11	23	3.6
Z8400-11G/15P	11.0/15	33	2
Z8400-15G/18.5P	15/18.5	33	2
Z8400-18.5G/22P	18.5/22	40	1.3
Z8400-22G/30P	22/30	50	1.08
Z8400-30G/37P	30/37	65	0.8
Z8400-37G/45P	37/45	78	0.7
Z8400-45G/55P	45/55	95	0.54
Z8400-55G/75P	55/75	115	0.45
Z8400-75G/90P	75/90	180	0.36
Z8400-90G/110P	90/110	180	0.33
Z8400-110G/132P	110/132	250	0.26
Z8400-132G/160P	132/160	250	0.26
Z8400-160G/185P	160/185	340	0.18
Z8400-185G/200P	185/200	460	0.12
Z8400-200G/220P	200/220	460	0.12
Z8400-220G/250P	220/250	460	0.12
Z8400-250G/280P	250/280	500	0.12
Z8400-280G/315P	280/315	650	0.11
Z8400-315G/350P	315/350	650	0.11
Z8400-350G/400P	350/400	800	0.06
Z8400-400G/450P	400/450	800	0.06
Z8400-450G/500P	450/500	1000	0.05
Z8400-500G/560P	500/560	1200	0.04
Z8400-560G/630P	560/630	1200	0.04
Z8400-630G/710P	630/710	1200	0.04

Applicable Inverter Type	Motor Output (kW)	DC Reactor Selection	
		Rated current (A)	Inductance value (mH)
Z8400-710G/800P	710/800	800*2	0.06
Z8400-800G/900P	800/900	800*2	0.06
Z8400-900G/1000P	900/1000	1000*2	0.05
Z8400-1000G	1000	1000*2	0.05

Install connection:

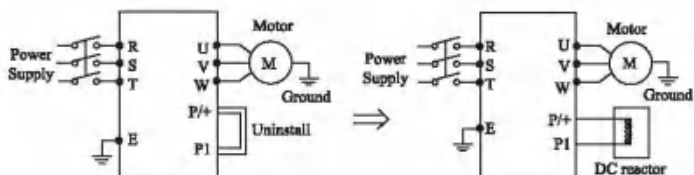

### 7-3 Applied AC reactor Specification

Applicable Inverter Type	Motor Output (kW)	AC Reactor Selection	
		Rated current (A)	Inductance value (mH)
Z8200-0R4G	0.4	2	7
Z8200-0R7G	0.75	2	7
Z8200-1R5G	1.5	5	3.8
Z8200-2R2G	2.2	7.5	2.5
Z8200-3R7G	3.7	20	0.75
Z8400-0R4G	0.4	5	3.8
Z8400-0R7G	0.75	5	3.8
Z8400-1R5G	1.5	5	3.8
Z8400-2R2G	2.2	7	2.5
Z8400-3R7G/5R5P	3.7/5.5	10	1.5
Z8400-5R5G/7R5P	5.5/7.5	15	1
Z8400-7R5G/11P	7.5/11	20	0.75
Z8400-11G/15P	11.0/15	30	0.6
Z8400-15G/18.5P	15/18.5	40	0.42
Z8400-18.5G/22P	18.5/22	50	0.35
Z8400-22G/30P	22/30	60	0.28
Z8400-30G/37P	30/37	80	0.19
Z8400-37G/45P	37/45	90	0.16
Z8400-45G/55P	45/55	120	0.13
Z8400-55G/75P	55/75	150	0.1
Z8400-75G/90P	75/90	200	0.12

Applicable Inverter Type	Motor Output (kW)	AC Reactor Selection	
		Rated current (A)	Inductance value (mH)
Z8400-90G/110P	90/110	250	0.06
Z8400-110G/132P	110/132	250	0.06
Z8400-132G/160P	132/160	290	0.04
Z8400-160G/185P	160/185	330	0.04
Z8400-185G/200P	185/200	400	0.04
Z8400-200G/220P	200/220	490	0.03
Z8400-220G/250P	220/250	490	0.03
Z8400-250G/280P	250/280	530	0.03
Z8400-280G/315P	280/315	600	0.02
Z8400-315G/350P	315/350	660	0.02
Z8400-350G/400P	350/400	800	0.0175
Z8400-400G/450P	400/450	800	0.0175
Z8400-450G/500P	450/500	1000	0.014
Z8400-500G/560P	500/560	1200	0.011
Z8400-560G/630P	560/630	1200	0.011
Z8400-630G/710P	630/710	1200	0.011
Z8400-710G/800P	710/800	1800	0.008
Z8400-800G/900P	800/900	1800	0.008
Z8400-900G/1000P	900/1000	1800	0.008
Z8400-1000G	1000	1800	0.008

Installation:

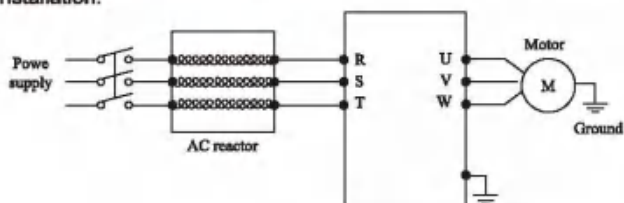

## 7-4 Applied Braking resistor Specification

Applicable Inverter Type	Brake resistor		Brake Unit CDBR	Motor Output (kW)
	Power (W)	Resistance Value( $\Omega$ ) ( $\geq$ )		
Z8200-0R4G	80W	200	embedded	0.4
Z8200-0R7G	80W	150		0.75
Z8200-1R5G	100W	100		1.5
Z8200-2R2G	100W	70		2.2
Z8200-3R7G	250W	65		3.7
Z8400-0R4G	150W	300		0.4
Z8400-0R7G	150W	300		0.75
Z8400-1R5G	150W	220		1.5
Z8400-2R2G	250W	200		2.2
Z8400-3R7G/5R5P	300W	130		3.7/5.5
Z8400-5R5G/7R5P	400W	90		5.5/7.5
Z8400-7R5G/11P	500W	65		7.5/11
Z8400-11G/15P	800W	43		11.0/15
Z8400-15G/18.5P	1000W	32		15/18.5
Z8400-18.5G/22P	4kW	24	18.5/22	
Z8400-22G/30P	4.5kW	24	optional (embedded)	22/30
Z8400-30G/37P	6kW	19.2		30/37
Z8400-37G/45P	7kW	14.8	external	37/45
Z8400-45G/55P	9kW	12.8		45/55
Z8400-55G/75P	11kW	9.6		55/75
Z8400-75G/90P	15kW	6.8		75/90
Z8400-90G/110P	9kW*2	9.3*2		90/110
Z8400-110G/132P	11kW*2	9.3*2		110/132
Z8400-132G/160P	13kW*2	6.2*2		132/160
Z8400-160G/185P	16kW*2	6.2*2		160/185
Z8400-185G/200P	19kW*2	2.5*2		185/200
Z8400-200G/220P	19kW*2	2.5*2		200/220
Z8400-220G/250P	21kW*2	2.5*2		220/250
Z8400-250G/280P	24kW*2	2.5*2		250/280
Z8400-280G/315P	27kW*2	2.5*2		280/315
Z8400-315G/350P	20kW*3	2.5*3		315/350
Z8400-350G/400P	23kW*3	2.5*3	350/400	
Z8400-400G/450P	26kW*3	2.5*3	400/450	
Z8400-450G/500P	29kW*3	2.5*3	450/500	
Z8400-500G/560P	17kW*3	2.5*3	500/560	

Applicable Inverter Type	Brake resistor		Brake Unit CDBR	Motor Output (kW)
	Power (W)	Resistance Value( $\Omega$ ) (z)		
Z8400-560G/630P	20kW*3	2.5*3	external	560/630
Z8400-630G/710P	22kW*3	2.5*3		630/710
Z8400-710G/800P	20kW*4	2.5*4		710/800
Z8400-800G/900P	20kW*4	2.5*4		800/900
Z8400-900G/1000P	22kW*4	2.5*4		900/1000
Z8400-1000G	20kW*5	2.5*5		1000

Note: \* 2 indicates two braking unit with its own braking resistor in parallel, \* 3 / \* 4 / \* 5 \* 2 the same meaning

Calculate of Braking resistor value:

The Braking resistor value is related to the DC currency when the inverter braking. For 380V power supply, the braking DC voltage is 800V-820V, and for 220V system, the DC voltage is 400V.

Moreover, the Braking resistor value is related to braking torque Mbr%, and to the differeH braking torque the Braking resistor values are differeH, and the calculation formula is as follow:

$$R = \frac{U_{dc}^2 \times 100}{P_{Motor} \times M_{br}\% \times \eta_{Transducer} \times \eta_{Motor}}$$

The braking power is related to braking torque and braking frequency. the foregoing illustration gives the braking torque as 125% and the frequency is 10%, and according to the differeH loading situations, the numbers in the illustration are for reference.

## Appendix A

### List of Function Parameters

If PP.00 is set to a non-zero number, parameter protection is enabled. You must enter the correct user password to enter the menu. To cancel the password protection function, enter with password and set PP.00 to 0.

Group P and Group C are standard function parameters. Group D includes the monitoring function parameters.

The symbols in the function code table are described as follows:

" ☆ ": The parameter can be modified when the AC drive is in either stop or running state.

" ★ ": The parameter cannot be modified when the AC drive is in the running state.

" ● ": The parameter is the actually measured value and cannot be modified.

" \* \* ": The parameter is factory parameter and can be set only by the manufacturer.

#### Standard Function Parameters

Function Code	Parameter Name	Setting Range	Default	Property
Group P0: Standard Function Parameters				
P0.00	G/P type display	1: G type (constant torque load) 2: P type (variable torque load e.g. fan and pump)	Model dependent	★
P0.01	Control mode selection	0: Voltage/Frequency (V/F) control 1: Sensorless flux vector control (SFVC) 2: Closed-loop vector control (CLVC)	0	★
P0.02	Command source selection	0: Operation panel control (LED off) 1: Terminal control (LED on) 2: Communication control (LED linking)	0	☆

## Appendix A List of Function Parameters

Function Code	Parameter Name	Setting Range	Default	Property
P0.03	Frequency source selection	Unit's digit (Frequency source) 0: Main frequency source X 1: X and Y operation(operation relationship determined by ten's digit) 2: Switchover between X and Y 3: Switchover between X and "X and Y operation" 4: Switchover between Y and "X and Y operation" Ten's digit (X and Y operation) 0: X+Y 1: X-Y 2: Maximum 3: Minimum	00	☆
P0.04	Main frequency source X selection	0: Digital setting (P0.10 preset frequency, can modify the UP/DOWN, power lost don't memory) 1: Digital setting (P0.10 preset frequency, can modify the UP/DOWN, power lost memory) 2: FIV 3: FIC 4: reserved 5: Pulse setting (X5 ) 6: Multistage instruction 7: Simple PLC 8: PID	0	★
P0.05	Auxiliary frequency source Y selection	The same as P0.04 (Main frequency source X selection)	0	★
P0.06	Auxiliary frequency source superposition Y range selection	0: Relative to the maximum frequency 1: Relative to the main frequency source X	0	☆
P0.07	Auxiliary frequency source superposition Y range	0%~150%	100%	☆
P0.08	Acceleration time 1	0.00s~65000s	Model dependent	☆

Function Code	Parameter Name	Setting Range	Default	Property
P0.09	Deceleration time 1	0.00s~65000s	Model dependent	☆
P0.10	Frequency preset	0.00Hz~maximum frequency	50.00Hz	☆
P0.11	Rotation direction	0: Same direction 1: Reverse direction	0	☆
P0.12	Maximum frequency	50.00Hz~320.00Hz	50.00Hz	★
P0.13	Upper limit frequency source	0: P0.12 1: FIV 2: FIC 3: reserved 4: PULSE settings 5: communication settings	0	★
P0.14	Upper limit frequency	Frequency lower limit P0.16~Maximum frequency P0.10	50.00Hz	☆
P0.15	Upper limit frequency offset	0.00Hz~Maximum frequency P0.12	0.00Hz	☆
P0.16	Frequency lower limit	0.00Hz~Upper limit frequency P0.14	0.00Hz	☆
P0.17	Carrier frequency	0.5kHz~16.0kHz	Model dependent	☆
P0.18	Carrier frequency adjustment with temperature	0: No 1: Yes	1	☆
P0.19	Acceleration/Deceleration time unit	0: 1s 1: 0.1s 2: 0.01s	1	★
P0.21	Frequency offset of auxiliary frequency source for X and Y operation	0.00Hz~Maximum frequency P0.12	0.00Hz	☆
P0.22	Frequency reference	1:0.1Hz 2:0.01Hz	2	★
P0.23	Retentive of digital setting frequency upon power	0:Not retentive 1:Retentive	0	☆

## Appendix A List of Function Parameters

Function Code	Parameter Name	Setting Range	Default	Property
P0.24	Acceleration/ Deceleration time base frequency	0:Maximum frequency (P0.12 ) 1:Set frequency 2:100Hz	0	★
P0.25	Base frequency for UP/DOWN modification during running	0: Running frequency 1: Set frequency	0	★
P0.26	Binding command source to frequency source	Unit's digit:Binding operation panel command to frequency source 0:No binding 1:Frequency source by digital setting 2:FIV 3: FIC 4:reserved 5: Pulse setting (X5 ) 6:Multi-reference 7:Simple PLC 8:PID 9:Communication setting Ten's digit:Binding terminal command to frequency source (0~9. same as unit's digit ) Hundred's digit:Binding communication command to frequency source (0~9. same as unit's digit )	000	☆
P0.27	Communication expansion card type	0:Modbus communication card 1:Profibus-DP communication card 2:CAN communication card	0	☆
Group P1:Start/Stop Control				
P1.00	Start mode	0: direct start 1: Rotational speed tracking restart 2: Pre-excited start (asynchronous motor)	0	☆
P1.01	Rotational speed tracking mode	0: From frequency at stop 1: From zero speed 2: From maximum frequency	0	★
P1.02	Rotational speed tracking speed	1~100	20	☆
P1.03	Startup frequency	0.00Hz~10.00Hz	0.00Hz	☆

Function Code	Parameter Name	Setting Range	Default	Property
P1.04	Startup frequency holding time	0.0s~100.0s	0.0s	★
P1.05	Startup DC braking current/ Pre-excited current	0%~100%	0%	★
P1.06	Startup DC braking time/ Pre-excited time	0.0s~100.0s	0.0s	★
P1.07	Acceleration/ Deceleration mode	0: Linear acceleration/ deceleration 1: S-curve acceleration/ deceleration A 2: S-curve acceleration/ deceleration B	0	★
P1.08	Time proportion of S-curve start segment	0.0%~ (100.0%-P1.09 )	30.0%	★
P1.09	Time proportion of S-curve end segment	0.0%~ (100.0%-P1.08 )	30.0%	★
P1.10	Stop mode	0: Decelerate to stop 1: Coast to stop	0	☆
P1.11	Initial frequency of stop DC braking	0.00Hz~maximum frequency	0.00Hz	☆
P1.12	Waiting time of stop DC braking	0.0s~100.0s	0.0s	☆
P1.13	Stop DC braking current	0%~100%	0%	☆
P1.14	Stop DC braking time	0.0s~100.0s	0.0s	☆
P1.15	Brake use ratio	0%~100%	100%	☆
Group P2: Motor Parameters				
P2.00	Motor type selection	0: Common asynchronous motor 1: Variable frequency asynchronous motor 2: Permanent magnetic synchronous motor	0	★
P2.01	Rated motor power	0.1kW~1000.0kW	Model dependent	★
P2.02	Rated motor voltage	1V~2000V	Model dependent	★

## Appendix A List of Function Parameters

Function Code	Parameter Name	Setting Range	Default	Property
P2.03	Rated motor current	0.01A~655.35A (AC drive power≤55kW) 0.1A~6553.5A (AC drive power>55kW)	Model dependent	★
P2.04	Rated motor frequency	0.01Hz~maximum frequency	Model dependent	★
P2.05	Rated motor rotational speed	1rpm~65535rpm	Model dependent	★
P2.06	Stator resistance (asynchronous motor)	0.001Ω~65.535Ω (AC drive power≤55kW) 0.0001Ω~6.5535Ω (AC drive power>55kW)	Model dependent	★
P2.07	Rotor resistance (asynchronous motor)	0.001Ω~65.535Ω (AC drive power≤55kW) 0.0001Ω~6.5535Ω (AC drive power>55kW)	Model dependent	★
P2.08	Leakage inductive reactance (asynchronous)	0.01mH~655.35mH (AC drive power≤55kW) 0.001mH~65.535mH (AC drive power>55kW)	Model dependent	★
P2.09	No-load current (asynchronous motor)	0.1mH~6553.5mH (AC drive power≤55kW) 0.01mH~655.35mH (AC drive power>55kW)	Model dependent	★
P2.10	Stator resistance (synchronous motor)	0.01A~P2.03 (AC drive power≤55kW) 0.1A~P2.03 (AC drive power>55kW)	Model dependent	★
P2.16	Shaft D inductance (synchronous motor)	0.001Ω~65.535Ω (AC drive power≤55kW) 0.0001Ω~6.5535Ω (AC drive power>55kW)	Model dependent	★
P2.17	Shaft Q inductance (synchronous motor)	0.01mH~655.35mH (AC drive power≤55kW) 0.001mH~65.535mH (AC drive power>55kW)	Model dependent	★
P2.18	Shaft Q inductance (synchronous motor)	0.01mH~655.35mH (AC drive power≤55kW) 0.001mH~65.535mH (AC drive power>55kW)	Model dependent	★
P2.20	Back EMF (synchronous motor)	0.1V~6553.5V	Model dependent	★
P2.27	Encoder pulses per revolution	1~65535	1024	★

Function Code	Parameter Name	Setting Range	Default	Property
P2.28	Encoder type	0: ABZ incremental encoder 1: UVW incremental encoder 2: Resolver 3: SIN/COS encoder 4: Wire-saving UVW encoder	2	★
P2.30	ABZ phase sequence of ABZ encoder	0: Forward 1: Reverse	0	★
P2.31	Encoder installation angle	0.0~359.9°	0.0°	★
P2.32	UVW phase sequence of UVW encoder	0: Forward 1: Reverse	0	★
P2.33	UVW encoder angle offset	0.0~359.9°	0.0°	★
P2.34	Number of pole pairs of resolver	1~65535	1	★
P2.36	Encoder wire-break fault detection time	0.0: No action 0.1s~10.0s	0.0	★
P2.37	Auto-tuning selection	0: No auto-tuning 1: Asynchronous motor static auto-tuning 2: Asynchronous motor complete auto-tuning 3: Synchronous motor with-load auto-tuning 4: Synchronous motor no-load auto-tuning	0	★
Group P3: Vector Control Parameters				
P3.00	Speed loop proportional gain 1	1~100	30	☆
P3.01	Speed loop integral time 1	0.01s~10.00s	0.50s	☆
P3.02	Switchover frequency 1	0.00~P3.05	5.00Hz	☆
P3.03	Speed loop proportional gain 2	1~100	20	☆
P3.04	Speed loop integral time 2	0.01s~10.00s	1.00s	☆
P3.05	Switchover frequency 2	P3.02~maximum output frequency	10.00Hz	☆

## Appendix A List of Function Parameters

Function Code	Parameter Name	Setting Range	Default	Property
P3.06	Vector control slip gain	50%~200%	100%	☆
P3.07	Time constant of speed loop filter	0.000s~0.100s	0.000s	☆
P3.08	Vector control over-excitation gain	0~200	64	☆
P3.09	Torque upper limit source in speed control mode	0: P3.10 1: FIV 2: FIC 3: reserved 4: Pulse setting 5: Communication setting 6: MIN (FIV,FIC ) 7: MAX (FIV,FIC )	0	☆
P3.10	digital setting of torque upper limit in speed control mode	0.0%~200.0%	150.0%	☆
P3.13	Excitation adjustment proportional gain	0~60000	2000	☆
P3.14	Excitation adjustment integral gain	0~60000	1300	☆
P3.15	Torque adjustment proportional gain	0~60000	2000	☆
P3.16	Torque adjustment integral gain	0~60000	1300	☆
P3.17	Speed loop integral property	Unit's digit: integral separation 0: Disabled 1: Enabled	0	☆
P3.18	Field weakening mode of synchronous motor	0:No field weakening 1:direct calculation 2:Automatic adjustment	1	☆
P3.19	Field weakening depth of synchronous motor	50%~500%	100%	☆

Function Code	Parameter Name	Setting Range	Default	Property
P3.20	Maximum field weakening current	1%~300%	50%	☆
P3.21	Field weakening automatic adjustment gain	10%~500%	100%	☆
P3.22	Field weakening integral multiple	2~10	2	☆
Group P4: V/F Control Parameters				
P4.00	V/F curve setting	0: Linear V/F 1: Multi-point V/F 2: Square V/F 3: 1.2-power V/F 4: 1.4-power V/F 6: 1.6-power V/F 8: 1.8-power V/F 9: Reserved 10: V/F complete separation 11: V/F half separation	0	★
P4.01	Torque boost	0.0%: (fixed torque boost ) 0.1%~30.0%	Model dependent	☆
P4.02	Cut-off frequency of torque boost	0.00Hz~maximum output frequency	50.00Hz	★
P4.03	Multi-point V/F frequency 1 (F1)	0.00Hz~P4.05	0.00Hz	★
P4.04	Multi-point V/F voltage 1 (V1)	0.0%~100.0%	0.0%	★
P4.05	Multi-point V/F frequency 2 (F2)	P4.03~P4.07	0.00Hz	★
P4.06	Multi-point V/F voltage 2 (V2)	0.0%~100.0%	0.0%	★
P4.07	Multi-point V/F frequency 3 (F3)	P4.05~rated motor frequency (P1.04 )	0.00Hz	★
P4.08	Multi-point V/F voltage 3 (V3)	0.0%~100.0%	0.0%	★
P4.09	V/F slip compensation gain	0.0%~200.0%	0.0%	☆
P4.10	V/F over-excitation gain	0~200	64	☆
P4.11	V/F oscillation suppression gain	0~100	Model dependent	☆

## Appendix A List of Function Parameters

Function Code	Parameter Name	Setting Range	Default	Property
P4.13	Voltage source for V/F separation	0: digital setting (P4.14 ) 1: FIV 2: FIC 3: reserved 4: PULSE setting (X5 ) 5: Multi-reference 6: Simple PLC 7: PID 8: Communication setting 100.0% corresponds to the rated motor voltage.	0	☆
P4.14	Voltage digital setting for V/F separation	0V~rated motor voltage	0V	☆
P4.15	Voltage rise time of V/F separation	0.0s~1000.0s It indicates the time for the voltage rising from 0 V to rated motor voltage.	0.0s	☆
P4.16	Voltage decline time of V/F separation	0.0s~1000.0s It indicates the time for the voltage to decline from rated motor voltage to 0 V.		
Group P5: Input Terminals				
P5.00	X1 function selection	0: No function 1: Forward RUN (FWD )	1	★
P5.01	X2 function selection	2: Reverse RUN (REV ) 3: Three-line control	4	★
P5.02	X3 function selection	4: Forward JOG (FJOG ) 5: Reverse JOG (RJOG ) 6: Terminal UP	9	★
P5.03	X4 function selection	7: Terminal DOWN 8: Coast to stop 9: Fault reset (RESET ) 10: RUN pause 11: Normally open (NO) input of external fault 12: Multi-reference terminal 1 13: Multi-reference terminal 2 14: Multi-reference terminal 3 15: Multi-reference terminal 4 16: Terminal 1 for acceleration/ deceleration time selection 17: Terminal 2 for acceleration/ deceleration time selection 18: Frequency source Switchover	12	★

## Operation Instruction of Z8000 Series Inverter

Function Code	Parameter Name	Setting Range	Default	Property
P5.04	X5 function selection	19: UP and DOWN setting clear (terminal, operation panel)	13	★
P5.05	X6 function selection	20: Command source switchover terminal	0	★
P5.06	X7 function selection	21: Acceleration/Deceleration Prohibited	0	★
P5.07	X8 function selection	22: PID pause	0	★
P5.08	reserved	23: PLC status reset		
P5.09	reserved	24: Swing pause 25: Counter input 26: Counter reset 27: Length count input 28: Length reset 29: Torque control prohibited 30: Pulse input (enabled only for X5 ) 31: Reserved 32: Immediate DC braking 33: Normally closed (NC) input of external fault 34: Frequency modification forbidden 35: Reverse PID action direction 36: External STOP terminal 1 37: Command source switchover terminal 2 38: PID integral pause 39: Switchover between main frequency source X and preset frequency 40: Switchover between auxiliary frequency source Y and preset frequency 41: reserved 42: reserved 43: PID parameter switchover 44: reserved 45: reserved 46: Speed control/Torque control switchover 47: Emergency stop 48: External STOP terminal 2 49: Deceleration DC braking 50: Clear the current running time 51-59:Reserved		
P5.10	X filter time	0.000s~1.000s	0.010s	☆

## Appendix A List of Function Parameters

Function Code	Parameter Name	Setting Range	Default	Property
P5.11	Terminal command mode	0: Two-line mode 1 1: Two-line mode 2 2: Three-line mode 1 3: Three-line mode 2	0	★
P5.12	Terminal UP/ DOWN rate	0.001Hz/s~65.535Hz/s	1.00Hz/s	☆
P5.13	FI curve 1 minimum input	0.00V~P5.15	0.00V	☆
P5.14	Corresponding setting of FI curve 1 minimum input	-100.0%~+100.0%	0.0%	☆
P5.15	FI curve 1 maximum input	P5.13~+10.00V	10.00V	☆
P5.16	Corresponding setting of FI curve 1 maximum input	-100.0%~+100.0%	100.0%	☆
P5.17	FI curve 1 filter time	0.00s~10.00s	0.10s	☆
P5.18	FI curve 2 minimum input	0.00V~P5.20	0.00V	☆
P5.19	Corresponding setting of FI curve 2 minimum input	-100.0%~+100.0%	0.0%	☆
P5.20	FI curve 2 maximum input	P5.18~+10.00V	10.00V	☆
P5.21	Corresponding setting of FI curve 2 maximum input	-100.0%~+100.0%	100.0%	☆
P5.22	FI curve 2 filter time	0.00s~10.00s	0.10s	☆
P5.23	FI curve 3 minimum input	-10.00V~P5.25	0V	☆
P5.24	Corresponding setting of FI curve 3 minimum input	-100.0%~+100.0%	0.0%	☆
P5.25	FI curve 3 maximum input	P5.23~+10.00V	10.00V	☆
P5.26	Corresponding setting of FI curve 3 maximum input	-100.0%~+100.0%	100.0%	☆

Function Code	Parameter Name	Setting Range	Default	Property
P5.27	FI curve 3 filter time	0.00s~10.00s	0.10s	☆
P5.28	PULSE minimum input	0.00kHz~P5.30	0.00kHz	☆
P5.29	Corresponding setting of pulse minimum input	-100.0%~100.0%	0.0%	☆
P5.30	PULSE maximum input	P5.28~100.00kHz	50.00kHz	☆
P5.31	Corresponding setting of pulse maximum input	-100.0%~100.0%	100.0%	☆
P5.32	PULSE filter time	0.00s~10.00s	0.10s	☆
P5.33	FI curve selection	Unit's digit: FIV curve selection 1: Curve 1 (2 points, see P5.13~P5.16) 2: Curve 2 (2 points, see P5.18~P5.21) 3: Curve 3 (2 points, see P5.23~P5.26) 4: Curve 4 (4 points, see C6.00~C6.07) 5: Curve 5 (4 points, see C6.08~C6.15) Ten's digit: FIC curve selection (1~5, same as FIV) Hundred's digit: reserved	321	☆
P5.34	Setting for FI less than minimum input	Unit's digit: Setting for FIV less than minimum input 0: Minimum value 1: 0.0% Ten's digit: Setting for FIC less than minimum input (0~1, same as FIV) Hundred's digit: reserved	000	☆
P5.35	X1 delay time	0.0s~3600.0s	0.0s	☆
P5.36	X2 delay time	0.0s~3600.0s	0.0s	☆
P5.37	X3 delay time	0.0s~3600.0s	0.0s	☆
P5.38	X valid mode selection 1	0: High level valid 1: Low level valid Unit's digit: X1 Ten's digit: X2 Hundred's digit: X3 Thousand's digit: X4 Ten thousand's digit: X5	00000	★

## Appendix A List of Function Parameters

Function Code	Parameter Name	Setting Range	Default	Property
P5.39	X valid mode selection 2	0: High level valid 1: Low level valid Unit's digit: X6 Ten's digit: X7 Hundred's digit: X8 Thousand's digit: reserved Ten thousand's digit: reserved	00000	★
Group P6: Output Terminals				
P6.00	YO terminal output mode	0: Pulse output (YO-P) 1: Switch signal output (YO-R)	0	☆
P6.01	YO-R function (open-collector output terminal)	0: No output 1: AC drive running 2: Fault output (stop) 3: Frequency-level detection FDT1 output 4: Frequency reached 5: Zero-speed running(no output at stop)	0	☆
P6.02	Relay output function (YA-YB-YC)	6: Motor overload pre-warning 7: AC drive overload pre-warning 8: Set count value Reached 9: Designated count value reached 10: Length reached 11: PLC cycle complete	2	☆
P6.03	Relay output function (RA-RB-RC)	12: Accumulative running time reached 13: Frequency limited 14: Torque limited 15: Ready for RUN 16: FIV>FIC 17: Frequency upper limit reached 18: Frequency lower limit reached (no output at stop) 19: Under voltage state output 20: Communication setting 21: Reserved 22: Reserved	0	☆

Function Code	Parameter Name	Setting Range	Default	Property
P6.04	reserved	23: Zero-speed running 2 (having output at stop) 24: Accumulative power-on time reached 25: Frequency level detection FDT2 output 26: Frequency 1 reached 27: Frequency 2 reached		
P6.05	reserved	28: Current 1 reached 29: Current 2 reached 30: Timing reached 31: FIV input limit exceeded 32: Load becoming 0 33: Reverse running 34: Zero current state 35: Module temperature reached 36: Software current limit exceeded 37: Frequency lower limit reached (having output at stop) 38: Alarm output 39: Motor overheat warning 40: Current running time reached		
P6.06	YO-P function selection	0: Running frequency 1: Set frequency 2: Output current 3: Output torque 4: Output power 5: Output voltage	0	☆
P6.07	FOV function selection	6: Pulse input (100.0% for 100.0kHz ) 7: FIV 8: FIC 9: reserved 10: Length 11: Count value	0	☆
P6.08	FOC function selection	12: Communication setting 13: Motor rotational speed 14: Output current (100.0% for 1000.0A ) 15: Output voltage (100.0% for 1000.0V ) 16: Reserved	1	☆
P6.09	Maximum YO-P output frequency	0.01kHz~100.00kHz	50.00kHz	☆

## Appendix A List of Function Parameters

Function Code	Parameter Name	Setting Range	Default	Property
P6.10	FOV offset coefficient	-100.0%~+100.0%	0.0%	☆
P6.11	FOV gain	-10.00~+10.00	1.00	☆
P6.12	FOC offset coefficient	-100.0%~+100.0%	0.0%	☆
P6.13	FOC gain	-10.00~+10.00	1.00	☆
P6.17	YO-R output delay time	0.0s~3600.0s	0.0s	☆
P6.18	YA-YB-YC output delay time	0.0s~3600.0s	0.0s	☆
P6.19	RA-RB-RC output delay time	0.0s~3600.0s	0.0s	☆
P6.20	reserved			
P6.21	reserved			
P6.22	YO valid mode selection	0: Positive logic 1: Negative logic Unit's digit: YOR Ten's digit: YA-YB-YC Hundred's digit: RA-RB-RC	00000	☆
<b>Group P7: Operation Panel and Display</b>				
P7.00	Power factor correction	0.0-200.0	100.0	☆
P7.01	JOG key function selection	0: JOG key disabled 1: Switchover between operation panel control and remote command control (terminal or communication) 2: Switchover between forward rotation and reverse rotation 3: Forward JOG 4: Reverse JOG	0	★
P7.02	STOP/RESET key function	0: STOP/RESET key enabled only in operation panel control 1: STOP/RESET key enabled in any operation mode	1	☆

Function Code	Parameter Name	Setting Range	Default	Property
P7.03	LED display running parameters 1	0000–FFFF Bit00: Running frequency 1 (Hz) Bit01: Set frequency (Hz) Bit02: Bus voltage (V) Bit03: Output voltage (V) Bit04: Output current (A) Bit05: Output power (kW) Bit06: Output torque (%) Bit07: X input status Bit08: YO output status Bit09: FIV voltage (V) Bit10: FIC voltage (V) Bit11: reserved Bit12: Count value Bit13: Length value Bit14: Load speed display Bit15: PID setting	1F	☆
P7.04	LED display running parameters 2	0000–FFFF Bit00: PID feedback Bit01: PLC stage Bit02: Pulse setting frequency(kHz) Bit03: Running frequency 2 (Hz) Bit04: Remaining running time Bit05: FIV voltage before correction (V) Bit06: FIC voltage before correction (V) Bit07: reserved Bit08: Linear speed Bit09: Current power-on time(Hour) Bit10: Current running time (Min) Bit11: Pulse setting frequency(Hz) Bit12: Communication setting value Bit13: Encoder feedback speed(Hz) Bit14: Main frequency X display(Hz) Bit15: Auxiliary frequency Y display (Hz)	0	☆

## Appendix A List of Function Parameters

Function Code	Parameter Name	Setting Range	Default	Property
P7.05	LED display stop parameters	0000~FFFF Bit00: Set frequency (Hz) Bit01: Bus voltage (V) Bit02: X input status Bit03: YO output status Bit04: FIV voltage (V) Bit05: FIC voltage (V) Bit06: reserved Bit07: Count value Bit08: Length value Bit09: PLC stage Bit10: Load speed Bit11: PID setting Bit12: Pulse setting frequency(kHz)	33	☆
P7.06	Load speed display coefficient	0.0001~6.5000	1.0000	☆
P7.07	Heatsink temperature of inverter	0.0°C~150.0°C	-	●
P7.08	Temporary software version	0.0°C~150.0°C	-	●
P7.09	Accumulative running time	0h~65535h	-	●
P7.10	reserved	-	-	●
P7.11	Software version	-	-	●
P7.12	Number of decimal places for load speed display	0: 0 decimal place 1: 1 decimal place 2: 2 decimal places 3: 3 decimal places	1	☆
P7.13	Accumulative power-on time	0h~65535h	-	●
P7.14	Accumulative power consumption	0kW~65535kWh	-	●
<b>Group P8: Auxiliary Functions</b>				
P8.00	JOG running frequency	0.00Hz~maximum frequency	2.00Hz	☆
P8.01	JOG acceleration time	0.0s~6500.0s	20.0s	☆
P8.02	JOG deceleration time	0.0s~6500.0s	20.0s	☆

Function Code	Parameter Name	Setting Range	Default	Property
P8.03	Acceleration time 2	0.0s~6500.0s	Model dependent	☆
P8.04	Deceleration time 2	0.0s~6500.0s	Model dependent	☆
P8.05	Acceleration time 3	0.0s~6500.0s	Model dependent	☆
P8.06	Deceleration time 3	0.0s~6500.0s	Model dependent	☆
P8.07	Acceleration time 4	0.0s~6500.0s	Model dependent	☆
P8.08	Deceleration time 4	0.0s~6500.0s	Model dependent	☆
P8.09	Jump frequency 1	0.00Hz~maximum frequency	0.00Hz	☆
P8.10	Jump frequency 2	0.00Hz~maximum frequency	0.00Hz	☆
P8.11	Frequency jump amplitude	0.00Hz~maximum frequency	0.00Hz	☆
P8.12	Forward/ Reverse rotation dead-zone time	0.0s~3000.0s	0.0s	☆
P8.13	Reverse control	0: Enabled 1: Disabled	0	☆
P8.14	Running mode when set frequency lower than frequency lower limit	0: Run at frequency lower limit 1: Stop 2: Run at zero speed	0	☆
P8.15	Droop control	0.00Hz~10.00Hz	0.00Hz	☆
P8.16	Accumulative power-on time threshold	0h~65000h	0h	☆
P8.17	Accumulative running time threshold	0h~65000h	0h	☆
P8.18	Startup protection	0: No 1: Yes	0	☆
P8.19	Frequency detection value (FDT1 )	0.00Hz~maximum frequency	50.00Hz	☆
P8.20	Frequency detection hysteresis (FDT1 )	0.0%~100.0% (FDT1 level )	5.0%	☆

## Appendix A List of Function Parameters

Function Code	Parameter Name	Setting Range	Default	Property
P8.21	Detection range of frequency reached	0.0%~100.0% (maximum frequency)	0.0%	☆
P8.22	Jump frequency during acceleration/ deceleration	0: Disabled 1: Enabled	1	☆
P8.25	Frequency switchover point between acceleration time 1 and acceleration time 2	0.00Hz~maximum frequency	0.00Hz	☆
P8.26	Frequency switchover point between deceleration time 1 and deceleration time 2	0.00Hz~maximum frequency	0.00Hz	☆
P8.27	Terminal JOG preferred	0: Disabled 1: Enabled	0	☆
P8.28	Frequency detection value (FDT2)	0.00Hz~maximum frequency	50.00Hz	☆
P8.29	Frequency detection hysteresis (FDT2)	0.0%~100.0% (FDT2 level)	5.0%	☆
P8.30	Any frequency reaching detection value 1	0.00Hz~maximum frequency	50.00Hz	☆
P8.31	Any frequency reaching detection amplitude 1	0.0%~100.0% (maximum frequency)	0.0%	☆
P8.32	Any frequency reaching detection value 2	0.00Hz~maximum frequency	50.00Hz	☆
P8.33	Any frequency reaching detection amplitude 2	0.0%~100.0% (maximum frequency)	0.0%	☆

Function Code	Parameter Name	Setting Range	Default	Property
P8.34	Zero current detection level	0.0%~300.0% 100.0% for rated motor current	5.0%	☆
P8.35	Zero current detection delay time	0.01s~600.00s	0.10s	☆
P8.36	Output over current threshold	0.0% (no detection ) 0.1%~300.0% (rated motor current )	200.0%	☆
P8.37	Output over current detection delay time	0.00s~600.00s	0.00s	☆
P8.38	Any current reaching 1	0.0%~300.0% (rated motor current )	100.0%	☆
P8.39	Any current reaching 1 amplitude	0.0%~300.0% (rated motor current )	0.0%	☆
P8.40	Any current reaching 2	0.0%~300.0% (rated motor current )	100.0%	☆
P8.41	Any current reaching 2 amplitude	0.0%~300.0% (rated motor current )	0.0%	☆
P8.42	Timing function	0:Disabled 1:Enabled	0	★
P8.43	Timing duration source	0: P8.44 1: FIV 2: FIC 3: reserved 100% of analog input corresponds to the value of P8.44	0	★
P8.44	Timing duration	0.0Min~6500.0Min	0.0Min	★
P8.45	FIV input voltage lower limit	0.00V~P8.46	3.10V	☆
P8.46	FIV input voltage upper limit	P8.45~10.00V	6.80V	☆
P8.47	Module temperature threshold	0°C~150°C	100°C	☆
P8.48	Cooling fan control	0: Fan working during running 1: Fan working continuously	0	☆
P8.49	Wakeup frequency	Dormant frequency (P8.51 ) ~maximum frequency (P0.12 )	0.00Hz	☆

## Appendix A List of Function Parameters

Function Code	Parameter Name	Setting Range	Default	Property
P8.50	Wakeup delay time	0.0s~6500.0s	0.0s	☆
P8.51	Dormant frequency	0.00Hz~wakeup frequency (P8.49)	0.00Hz	☆
P8.52	Dormant delay time	0.0s~6500.0s	0.0s	☆
P8.53	Current running time reached	0.0Min~6500.0Min	0.0Min	★
Group P9: Fault and Protection				
P9.00	Motor overload protection selection	0: Disabled 1: Enabled	1	☆
P9.01	Motor overload protection gain	0.20~10.00	1.00	☆
P9.02	Motor overload warning coefficient	50%~100%	80%	☆
P9.03	Overvoltage stall gain	0~100	10	☆
P9.04	Overvoltage stall protective voltage	120%~150%	130%	☆
P9.05	Over current stall gain	0~100	20	☆
P9.06	Over current stall protective current	100%~200%	150%	☆
P9.07	Short-circuit to ground upon power-on	0: Disabled 1: Enabled	1	☆
P9.09	Fault auto reset times	0~20	0	☆
P9.10	YO action during fault auto reset	0: Not act 1: Act	0	☆
P9.11	Time interval of fault auto reset	0.1s~100.0s	1.0s	☆
P9.12	Input phase loss protection selection	0: Disabled 1: Enabled	1	☆
P9.13	Output phase loss protection selection	0: Disabled 1: Enabled	1	☆

Function Code	Parameter Name	Setting Range	Default	Property
P9.14	1st fault type	0: No fault		●
P9.15	2nd fault type	1: Reserved	-	●
P9.16	3rd (latest) fault type	2: Overcurrent during acceleration 3: Overcurrent during deceleration 4: Overcurrent at constant speed 5: Overvoltage during acceleration 6: Overvoltage during deceleration 7: Overvoltage at constant speed 8: Buffer resistance overload 9: Undervoltage 10: AC drive overload 11: Motor overload 12: Power input phase loss 13: Power output phase loss 14: Module overheat 15: External equipment fault 16: Communication fault 17: Contactor fault 18: Current detection fault 19: Motor auto-tuning fault 20: Encoder/PG card fault 21: EEPROM read-write fault 22: AC drive hardware fault 23: Short circuit to ground 24: Reserved 25: Reserved 26: Accumulative running time reached 27: reserved 28: reserved 29: Accumulative power-on time reached 30: Load becoming 0 31: PID feedback lost during running 40: With-wave current limit fault 41: Motor switchover fault during running 42: Too large speed deviation 43: Motor over-speed 45: reserved 51: Initial position fault	-	●

## Appendix A List of Function Parameters

Function Code	Parameter Name	Setting Range	Default	Property
P9.17	Frequency upon 3rd fault	-	-	●
P9.18	Current upon 3rd fault	-	-	●
P9.19	Bus voltage upon 3rd fault	-	-	●
P9.20	Input terminal status upon 3rd fault	-	-	●
P9.21	Output terminal status upon 3rd fault	-	-	●
P9.22	AC drive status upon 3rd fault	-	-	●
P9.23	Power-on time upon 3rd fault	-	-	●
P9.24	Running time upon 3rd fault	-	-	●
P9.27	Frequency upon 2nd fault	-	-	●
P9.28	Current upon 2nd fault	-	-	●
P9.29	Bus voltage upon 2nd fault	-	-	●
P9.30	X status upon 2nd fault	-	-	●
P9.31	Output terminal status upon 2nd fault	-	-	●
P9.32	Frequency upon 2nd fault	-	-	●
P9.33	Current upon 2nd fault	-	-	●
P9.34	Bus voltage upon 2nd fault	-	-	●
P9.37	X status upon 1st fault	-	-	●
P9.38	Output terminal status upon 1st fault	-	-	●
P9.39	Frequency upon 1st fault	-	-	●
P9.40	Current upon 1st fault	-	-	●

Function Code	Parameter Name	Setting Range	Default	Property
P9.41	Bus voltage upon 3rd fault	-	-	●
P9.42	X status upon 1st fault	-	-	●
P9.43	Output terminal status upon 1st fault	-	-	●
P9.44	Frequency upon 1st fault	-	-	●
P9.47	Fault protection action selection 1	Unit's digit: Motor overload (OL1) 0: Coast to stop 1: Stop according to the stop mode 2: Continue to run Ten's digit: Power input phase loss (LI) Hundred's digit: Power output phase loss (LO) Thousand's digit: External equipment fault (EF) Ten thousand's digit: Communication fault (CE)	00000	☆
P9.48	Fault protection action selection 2	Unit's digit: Encoder fault (PG) 0: Coast to stop Ten's digit: EEPROM read-write fault (EEP) 0: Coast to stop 1: Stop according to the stop mode Hundred's digit: reserved Thousand's digit: reserved Ten thousand's digit: Accumulative running time reached (END1)	00000	☆

## Appendix A List of Function Parameters

Function Code	Parameter Name	Setting Range	Default	Property
P9.49	Fault protection action selection 3	Unit's digit: reserved 0: Coast to stop 1: Stop according to the stop mode 2: Continue to run Ten's digit: reserved 0: Coast to stop 1: Stop according to the stop mode 2: Continue to run Hundred's digit: Accumulative power-on time reached (END2) 0: Coast to stop 1: Stop according to the stop mode 2: Continue to run Thousand's digit: Load becoming 0 0: Coast to stop 1: Stop according to the stop mode 2: Continue to run at 7% of rated motor frequency and resume to the set frequency if the load recovers 0: Coast to stop 1: Stop according to the stop mode 2: Continue to run	00000	☆
P9.50	Fault protection action selection 4	Unit's digit: Too large speed deviation (ESP) 0: Coast to stop 1: Stop according to the stop mode 2: Continue to run Ten's digit: Motor over-speed (OSP) Hundred's digit: Initial position fault (INI)	00000	☆
P9.54	Frequency selection for continuing to run	0: Current running frequency 1: Set frequency 2: Frequency upper limit 3: Frequency lower limit 4: Backup frequency upon abnormality	0	☆

Function Code	Parameter Name	Setting Range	Default	Property
P9.55	Backup frequency upon abnormality	60.0%~100.0%	100.0%	☆
P9.56	reserved			☆
P9.57	reserved			☆
P9.58	reserved			☆
P9.59	Action selection at instantaneous power failure	0: Invalid 1: Decelerate 2: Decelerate to stop	0	☆
P9.60	Action pause judging voltage at instantaneous power failure	0.0%~100.0%	90.0%	☆
P9.61	Voltage rally judging time at instantaneous power failure	0.00s~100.00s	0.50s	☆
P9.62	Action judging voltage at instantaneous power failure	60.0%~100.0% (standard bus voltage )	80.0%	☆
P9.63	Protection upon load becoming 0	0: Disabled 1: Enabled	0	☆
P9.64	Detection level of load becoming 0	0.0~100.0%	10.0%	☆
P9.65	Detection time of load becoming 0	0.0~60.0s	1.0s	☆
P9.67	Over-speed detection value	0.0%~50.0% (maximum frequency )	20.0%	☆
P9.68	Over-speed detection time	0.0s~60.0s	1.0s	☆
P9.69	Detection value of too large speed deviation	0.0%~50.0% (maximum frequency )	20.0%	☆
P9.70	Detection time of too large speed deviation	0.0s~60.0s	5.0s	☆
Group PA: Process Control PID Function				

## Appendix A List of Function Parameters

Function Code	Parameter Name	Setting Range	Default	Property
PA.00	PID setting source	0: PA.01 1: FIV 2: FIC 3: reserved 4: PULSE setting (X5) 5: Communication setting 6: Multi-reference	0	☆
PA.01	PID digital setting	0.0%~100.0%	50.0%	☆
PA.02	PID feedback source	0: FIV 1: FIC 2: reserved 3: FIV-FIC 4: PULSE setting (X5) 5: Communication setting 6: FIV+FIC 7: MAX ( FIV ,  FIC ) 8: MIN ( FIV ,  FIC )	0	☆
PA.03	PID action direction	0: Forward action 1: Reverse action	0	☆
PA.04	PID setting feedback range	0~65535	1000	☆
PA.05	Proportional gain Kp1	0.0~100.0	20.0	☆
PA.06	Integral time TI1	0.01s~10.00s	2.00s	☆
PA.07	Differential time Td1	0.000s~10.000s	0.000s	☆
PA.08	Cut-off frequency of PID reverse rotation	0.00~maximum frequency	2.00Hz	☆
PA.09	PID deviation limit	0.0%~100.0%	0.0%	☆
PA.10	PID differential limit	0.00%~100.00%	0.10%	☆
PA.11	PID setting change time	0.00~650.00s	0.00s	☆
PA.12	PID feedback filter time	0.00~60.00s	0.00s	☆
PA.13	PID output filter time	0.00~60.00s	0.00s	☆
PA.14	reserved	-	-	☆
PA.15	Proportional gain Kp2	0.0~100.0	20.0	☆

Function Code	Parameter Name	Setting Range	Default	Property
PA.16	Integral time T <sub>I2</sub>	0.01s~10.00s	2.00s	☆
PA.17	Differential time T <sub>d2</sub>	0.000s~10.000s	0.000s	☆
PA.18	PID parameter switchover condition	0: No switchover 1: Switchover via X 2: Automatic switchover based on deviation	0	☆
PA.19	PID parameter switchover deviation 1	0.0%~PA.20	20.0%	☆
PA.20	PID parameter switchover deviation 2	PA.19~100.0%	80.0%	☆
PA.21	PID initial value	0.0%~100.0%	0.0%	☆
PA.22	PID initial value holding time	0.00~650.00s	0.00s	☆
PA.23	Maximum deviation between two PID outputs in forward	0.00%~100.00%	1.00%	☆
PA.24	Maximum deviation between two PID outputs in reverse	0.00%~100.00%	1.00%	☆
PA.25	PID integral property	Unit's digit: Integral separated 0: Invalid 1: Valid Ten's digit: Whether to stop integral operation when the output reaches 0: Continue integral operation 1: Stop integral operation	00	☆
PA.26	Detection value of PID feedback loss	0.0%: Not judging feedback loss 0.1%~100.0%	0.0%	☆
PA.27	Detection time of PID feedback loss	0.0s~20.0s	0.0s	☆
PA.28	PID operation at stop	0: No PID operation at stop 1: PID operation at stop	0	☆
Group Pb: Swing Frequency, Fixed Length and Count				

## Appendix A List of Function Parameters

Function Code	Parameter Name	Setting Range	Default	Property
Pb.00	Swing frequency setting mode	0: Relative to the central frequency 1: Relative to the maximum frequency	0	☆
Pb.01	Swing frequency amplitude	0.0%~100.0%	0.0%	☆
Pb.02	Jump frequency amplitude	0.0%~50.0%	0.0%	☆
Pb.03	Swing frequency cycle	0.1s~3000.0s	10.0s	☆
Pb.04	Triangular wave rising time coefficient	0.1%~100.0%	50.0%	☆
Pb.05	Set length	0m~65535m	1000m	☆
Pb.06	Actual length	0m~65535m	0m	☆
Pb.07	Number of pulses per meter	0.1~6553.5	100.0	☆
Pb.08	Set count value	1~65535	1000	☆
Pb.09	Designated count value	1~65535	1000	☆
Group PC: Multi-Reference and Simple PLC Function				
PC.00	Reference 0	-100.0%~100.0%	0.0%	☆
PC.01	Reference 1	-100.0%~100.0%	0.0%	☆
PC.02	Reference 2	-100.0%~100.0%	0.0%	☆
PC.03	Reference 3	-100.0%~100.0%	0.0%	☆
PC.04	Reference 4	-100.0%~100.0%	0.0%	☆
PC.05	Reference 5	-100.0%~100.0%	0.0%	☆
PC.06	Reference 6	-100.0%~100.0%	0.0%	☆
PC.07	Reference 7	-100.0%~100.0%	0.0%	☆
PC.08	Reference 8	-100.0%~100.0%	0.0%	☆
PC.09	Reference 9	-100.0%~100.0%	0.0%	☆
PC.10	Reference 10	-100.0%~100.0%	0.0%	☆
PC.11	Reference 11	-100.0%~100.0%	0.0%	☆
PC.12	Reference 12	-100.0%~100.0%	0.0%	☆
PC.13	Reference 13	-100.0%~100.0%	0.0%	☆
PC.14	Reference 14	-100.0%~100.0%	0.0%	☆
PC.15	Reference 15	-100.0%~100.0%	0.0%	☆

Function Code	Parameter Name	Setting Range	Default	Property
PC.16	Simple PLC running mode	0: Stop after the AC drive runs one cycle 1: Keep final values after the AC drive runs one cycle 2: Repeat after the AC drive runs one cycle	0	☆
PC.17	Simple PLC retentive selection	Unit's digit: Retentive upon power failure 0: No 1: Yes Ten's digit: Retentive upon stop 0: No 1: Yes	00	☆
PC.20	Running time of simple PLC reference 1	0.0s (h )~6500.0s (h )	0.0s (h )	☆
PC.21	Acceleration/ deceleration time of simple PLC reference 1	0~3	0	☆
PC.22	Running time of simple PLC reference 2	0.0s (h )~6500.0s (h )	0.0s (h )	☆
PC.23	Acceleration/ deceleration time of simple PLC reference 2	0~3	0	☆
PC.24	Running time of simple PLC reference 3	0.0s (h )~6500.0s (h )	0.0s (h )	☆
PC.25	Acceleration/ deceleration time of simple PLC reference 3	0~3	0	☆
PC.26	Running time of simple PLC reference 4	0.0s (h )~6500.0s (h )	0.0s (h )	☆
PC.27	Acceleration/ deceleration time of simple PLC reference 4	0~3	0	☆
PC.28	Running time of simple PLC reference 5	0.0s (h )~6500.0s (h )	0.0s (h )	☆

## Appendix A List of Function Parameters

Function Code	Parameter Name	Setting Range	Default	Property
PC.29	Acceleration/ deceleration time of simple PLC reference 5	0~3	0	☆
PC.30	Running time of simple PLC reference 6	0.0s (h )~6500.0s (h )	0.0s (h )	☆
PC.31	Acceleration/ deceleration time of simple PLC reference 6	0~3	0	☆
PC.32	Running time of simple PLC reference 7	0.0s (h )~6500.0s (h )	0.0s (h )	☆
PC.33	Acceleration/ deceleration time of simple PLC reference 7	0~3	0	☆
PC.34	Running time of simple PLC reference 8	0.0s (h )~6500.0s (h )	0.0s (h )	☆
PC.35	Acceleration/ deceleration time of simple PLC reference 8	0~3	0	☆
PC.36	Running time of simple PLC reference 9	0.0s (h )~6500.0s (h )	0.0s (h )	☆
PC.37	Acceleration/ deceleration time of simple PLC reference 9	0~3	0	☆
PC.38	Running time of simple PLC reference 10	0.0s (h )~6500.0s (h )	0.0s (h )	☆
PC.39	Acceleration/ deceleration time of simple PLC reference 10	0~3	0	☆
PC.40	Running time of simple PLC reference 11	0.0s (h )~6500.0s (h )	0.0s (h )	☆

Function Code	Parameter Name	Setting Range	Default	Property
PC.41	Acceleration/ deceleration time of simple PLC reference 11	0~3	0	☆
PC.42	Running time of simple PLC reference 12	0.0s (h )~6500.0s (h )	0.0s (h )	☆
PC.43	Acceleration/ deceleration time of simple PLC reference 12	0~3	0	☆
PC.44	Running time of simple PLC reference 13	0.0s (h )~6500.0s (h )	0.0s (h )	☆
PC.45	Acceleration/ deceleration time of simple PLC reference 13	0~3	0	☆
PC.46	Running time of simple PLC reference 14	0.0s (h )~6500.0s (h )	0.0s (h )	☆
PC.47	Acceleration/ deceleration time of simple PLC reference 14	0~3	0	☆
PC.48	Running time of simple PLC reference 15	0.0s (h )~6500.0s (h )	0.0s (h )	☆
PC.49	Acceleration/ deceleration time of simple PLC reference 15	0~3	0	☆
PC.50	Time unit of simple PLC running	0: s (second ) 1: h (hour )	0	☆

## Appendix A List of Function Parameters

Function Code	Parameter Name	Setting Range	Default	Property
PC.51	Reference 0 source	0: Set by PC.00 1: FIV 2: FIC 3: reserved 4: PULSE setting 5: PID Set by preset frequency (P010), modified via terminal UP/DOWN	0	☆
<b>Group PD: Communication Parameters</b>				
PD.00	Baud rate	Unit's digit: MODBUS 0: 300BPS 1: 600BPS 2: 1200BPS 3: 2400BPS 4: 4800BPS 5: 9600BPS 6: 19200BPS 7: 38400BPS 8: 57600BPS 9: 115200BPS Ten's digit : reserved Hundred's digit: reserved Thousand's digit: reserved	0005	☆
PD.01	Data format	0: No check, data format <8,N,2> 1: Even parity check, data format<8,E,1> 2: Odd Parity check, data format<8,O,1> 3: No check, data format <8,N,1> Valid for Modbus	3	☆
PD.02	Local address	1~247, 0: Broadcast address	1	☆
PD.03	Response delay	0ms~20ms	2	☆
PD.04	Communication timeout	0.0 (invalid) , 0.1s~60.0s	0.0	☆
PD.05	Modbus protocol selection	Unit's digit: Modbus protocol 0: Non-standard Modbus protocol 1: Standard Modbus protocol Ten's digit: reserved	1	☆
PD.06	Communication reading current resolution	0: 0.01A 1: 0.1A	1	☆
<b>Group PE: reserved</b>				
<b>Group PP: User-Defined Function Codes</b>				

Function Code	Parameter Name	Setting Range	Default	Property
PP.00	User password	0~65535	0	☆
PP.01	Restore default settings	0: No operation 01: Restore factory settings except motor parameters 02: Clear records 04: Restore user backup parameters 501: Back up current user parameters	0	★
Group C0: Torque Control and Restricting Parameters				
C0.00	Speed/Torque control selection	0: Speed control 1: Torque control	0	★
C0.01	Torque setting source in torque control	0: Digital setting (C0.03) 1: FIV 2: FIC 3: reserved 4: PULSE setting 5: Communication setting 6: MIN (FIV,FIC) 7: MAX (FIV,FIC)	0	★
C0.03	Torque digital setting in	-200.0%~200.0%	150.0%	☆
C0.05	Forward maximum frequency in torque control	0.00Hz~maximum frequency	50.00Hz	☆
C0.06	Reverse maximum frequency in torque control	0.00Hz~maximum frequency	50.00Hz	☆
C0.07	Acceleration time in torque control	0.00s~650.00s	0.00s	★
C0.08	Deceleration time in torque control	0.00s~650.00s	0.00s	☆
Group C1-C4: reserved				
Group C5: Control Optimization Parameters				
C5.00	PWM switchover frequency upper limit	0.00Hz~15.00Hz	12.00Hz	☆
C5.01	PWM modulation mode	0: Asynchronous modulation 1: Synchronous modulation	0	☆

## Appendix A List of Function Parameters

Function Code	Parameter Name	Setting Range	Default	Property
C5.02	Dead zone compensation mode selection	0: No compensation 1: Compensation mode 1 2: Compensation mode 2	1	☆
C5.03	Random PWM depth	0: Random PWM invalid 1-10	0	☆
C5.04	Rapid current limit	0: Disabled 1: Enabled	1	☆
C5.05	Current detection compensation	0~100	5	☆
C5.06	Undervoltage threshold	60.0%~140.0%	100.0%	☆
C5.07	SFVC optimization mode selection	0: No optimization 1: Optimization mode 1 2: Optimization mode 2	1	★
Group C6: FI Curve Setting(FI Is FIV or FIC)				
C6.00	FI curve 4 minimum input	0.00V~C6.02	0.00V	☆
C6.01	Corresponding setting of FI curve 4 minimum input	-100.0%~+100.0%	0.0%	☆
C6.02	FI curve 4 inflexion 1 input	C6.00~C6.04	3.00V	☆
C6.03	Corresponding setting of FI curve 4 inflexion 1 input	-100.0%~+100.0%	30.0%	☆
C6.04	FI curve 4 inflexion 2 input	C6.02~C6.06	6.00V	☆
C6.05	Corresponding setting of FI curve 4 inflexion 2 input	-100.0%~+100.0%	60.0%	☆
C6.06	FI curve 4 maximum input	C6.06~+10.00V	10.00V	☆
C6.07	Corresponding setting of FI curve 4 maximum input	-100.0%~+100.0%	100.0%	☆
C6.08	FI curve 5 minimum input	0.00V~C6.10	0.00V	☆

Function Code	Parameter Name	Setting Range	Default	Property
C6.09	Corresponding setting of FI curve 5 minimum input	-100.0%~+100.0%	0.0%	☆
C6.10	FI curve 5 inflexion 1 input	C6.08~C6.12	3.00V	☆
C6.11	Corresponding setting of FI curve 5 inflexion 1 input	-100.0%~+100.0%	30.0%	☆
C6.12	FI curve 5 inflexion 2 input	C6.10~C6.14	6.00V	☆
C6.13	Corresponding setting of FI curve 5 inflexion 2 input	-100.0%~+100.0%	60.0%	☆
C6.14	FI curve 5 maximum input	C6.12~+10.00V	10.00V	☆
C6.15	Corresponding setting of FI curve	-100.0%~+100.0%	100.0%	☆
C6.16	Jump point of FIV	-100.0%~100.0%	0.0%	☆
C6.17	Jump amplitude of FIV input	0.0%~100.0%	0.5%	☆
C6.18	Jump point of FIC input	-100.0%~100.0%	0.0%	☆
C6.19	Jump amplitude of FIC input	0.0%~100.0%	0.5%	☆
Group CC: FI/FO Correction				
CC.00	FIV measured voltage 1	0.500V~4.000V	Factory-corrected	☆
CC.01	FIV displayed voltage 1	0.500V~4.000V	Factory-corrected	☆
CC.02	FIV measured voltage 2	6.000V~9.999V	Factory-corrected	☆
CC.03	FIV displayed voltage 2	6.000V~9.999V	Factory-corrected	☆
CC.04	FIC measured voltage 1	0.500V~4.000V	Factory-corrected	☆
CC.05	FIC displayed voltage 1	0.500V~4.000V	Factory-corrected	☆
CC.06	FIC measured voltage 2	6.000V~9.999V	Factory-corrected	☆

## Appendix A List of Function Parameters

Function Code	Parameter Name	Setting Range	Default	Property
CC.07	FIC displayed voltage 2	6.000V~9.999V	Factory-corrected	☆
CC.12	FOV target voltage 1	0.500V~4.000V	Factory-corrected	☆
CC.13	FOV measured voltage 1	0.500V~4.000V	Factory-corrected	☆
CC.14	FOV target voltage 2	6.000V~9.999V	Factory-corrected	☆
CC.15	FOV measured voltage 2	6.000V~9.999V	Factory-corrected	☆
CC.16	FOC target voltage 1	0.500V~4.000V	Factory-corrected	☆
CC.17	FOC measured voltage 1	0.500V~4.000V	Factory-corrected	☆
CC.18	FOC target voltage 2	6.000V~9.999V	Factory-corrected	☆
CC.19	FOC measured voltage 2	6.000V~9.999V	Factory-corrected	☆

<b>Group D0: Monitoring Parameters</b>		
Function Code	Parameter Name	Unit
D0.00	Running frequency (Hz )	0.01Hz
D0.01	Set frequency (Hz )	0.01Hz
D0.02	Bus voltage (V )	0.1V
D0.03	Output voltage (V )	1V
D0.04	Output current (A )	0.01A
D0.05	Output power (kW )	0.1kW
D0.06	Output torque (%)	0.1%
D0.07	X input state	1
D0.08	YO output state	1
D0.09	FIV voltage (V )	0.01V
D0.10	FIC voltage (V )	0.01V
D0.11	reserved	
D0.12	Count value	1
D0.13	Length	1
D0.14	Load speed	1
D0.15	PID setting	1
D0.16	PID feedback	1
D0.17	PLCstage	1
D0.18	Input pulse frequency	0.01kHz

D0.19	Feedback speed	0.1Hz
D0.20	Remaining running time	0.1Min
D0.21	FIV voltage before correction	0.001V
D0.22	FIC voltage before correction	0.001V
D0.23	reserved	
D0.24	Linear speed	1m/Min
D0.25	On the current time	1Min
D0.26	The current running time	0.1Min
D0.27	Pulse input frequency	1Hz
D0.28	Communication setting value	0.01%
D0.29	Encoder feedback speed	0.01Hz
D0.30	Main frequency X	0.01Hz
D0.31	Auxiliary frequency Y	0.01Hz
D0.32	View any memory address values	1
D0.33	Synchronous motor rotor position	0.1°
D0.34	Motor temperature	1°C
D0.35	Target torque	0.1%
D0.36	Resolver position	1
D0.37	Power factor angle	0.1°
D0.38	ABZ position	1
D0.39	Target voltage upon V/F separation	1V
D0.40	Output voltage upon V/F separation	1V
D0.41	X state visual display	1
D0.42	YO state visual display	1
D0.43	X function state visual display 1	1
D0.44	X function state visual display 2	1
D0.45	Current fault code	0

## Appendix B

# Communication Protocol

Z8000 series inverter provides RS232 / RS485 communication interface, and support the Modbus communication protocol. Users can be achieved by computing machine or PLC central control, through the communication protocol set frequency converter running commands, modify or read function code parameters, read the inverter working condition and fault information, etc.

1, the agreement content

The serial communication protocol defines the serial communication transmission of information content and format. Including: host polling or wide planting format; Host encoding method, the content includes: the function of the required action code, data transmission and error checking, etc. From the ring of machine should be used is the same structure, content including: action confirmation, return the data and error checking, etc.

If there was an error in receiving information from a machine, or cannot achieve the requirements of the host, it will organize a fault feedback information in response to the host. Application mode converter with RS232 / RS485 bus access to the "from" single main PC/PLC control network.

### Bus structure

(1) The interface way RS232 / RS485 interface hardware

(2) Asynchronous serial transmission mode, half-duplex transmission mode. At the same time the host and the only one to send data from the machine and the other can only receive data. Data in the process of serial asynchronous communication, the form of a message, a frame of a frame to send

(3) Topological structure from single host machine system. From the machine address set in the range of 1 ~ 247, 0 for broadcast communication address. In the network from the machine address must be unique.

### Agreement that

Z8000 series inverter is a kind of asynchronous serial port communication protocol of master-slave Modbus communication protocol, the network has only one equipment (host) to establish

agreement (called "query/command"). Other equipment (machine) can only by providing data response of the main machine "query/command", or "query/command" according to the host to make the corresponding action. Host in this refers to the personal computer (PC), industrial control equipment or programmable logic controller (PLC), etc., from machine refers to Z8000 inverter. The host can communicate to a separate from the machine, also can to all under a broadcast information from machine release. For access to the host alone "query/command", from the machine to return to a information (called response), for radio host information, from the machine without feedback response to the host.

Communication data structure Z8000 series frequency converter of the Modbus protocol communication data format is as follows: using the RTU mode, messages are sent at least begin with 3.5 characters pause time interval.

In network wave rate under varied characters of the time, this is the most easy to implement (below T1, T2, T3, T4). Transmission equipment is the first domain address.

The transmission character of you can use is the hex 0...9, A...F. Continuously detect network bus network facilities, including pause interval of time. When the first domain (domain) to receive, every equipment decoding to determine whether to own. After the last transmission character, a pause at least 3.5 characters time calibration for the end of the message. A new message can be started after the pause.

The entire message frame must be as a continuous flow of transmission. If the time frame to complete more than 1.5 characters before pause time, receiving equipment will refresh incomplete message and assume that the next byte is a new message the address of the domain. Likewise, if a new message in less than 3.5 characters of time and then a message before, receiving equipment will think it is a continuation of the previous message. This will result in an error, because in the final CRC field value can't be right.

RTU frame format:

The frame header START	3.5 characters
Slave address ADR	Communication address: 1~247
command code CMD	03: Read the machine parameters; 06: write the machine parameters
Date content DATA (N-1 )	Information content: Function code parameter address, function code number of parameters, function code parameter values, etc
Data content DATA (N-2 )	
.....	
Data content DATA0	

high-order position of CRC CHK	estimated value: CRC value
low-order position of CRC CHK	
END	3.5 characters'time

CMD (Command instruction ) and DATA (the description of data word )

command code: 03H, read N word (Word ) (Can read the most words of 12 ) For example,From the machine address of 01 inverter startup F105 continuous read for two consecutive values

The host command information

ADR	01H
CMD	03H
high-order position of the starting address	F1H
low-order position of the starting address	05H
high-order position of register	00H
low-order position of register	02H
low-order position of CRC CHK	Wait to calculate the CRC CHK values
high-order position of CRC CHK	

In response to information from the slave machine

Set PD.05 to 0:

ADR	01H
CMD	03H
high-order position of bytes	00H
low-order position of bytes	04H
Data high-order position of F002H	00H
Data low-order position of F002H	00H
Data high-order position of F003H	00H
Data low-order position of F003H	01H
low-order position of CRC CHK	Wait to calculate the CRC CHK values
high-order position of CRC CHK	

Set PD.05 to 1:

ADR	01H
CMD	03H
The number of bytes	04H
Data high-order position of F002H	00H
Data low-order position of F002H	00H
Data high-order position of F003H	00H
Data low-order position of F003H	01H
low-order position of CRC CHK	Wait to calculate the CRC CHK values
high-order position of CRC CHK	

The command code: 06H write a word (Word ) For example,write 000 (BB8H ) to slave machine.

Address 05H frequency converter's F00AH address.

The host command information

ADR	05H
CMD	06H
high-order position of data address	F0H
low-order position of data address	0AH
high-order position of information content	0BH
low-order position of information content	B8H
low-order position of CRC CHK	Wait to calculate the CRC CHK values
high-order position of CRC CHK	

In response to information from the slave machine

ADR	02H
CMD	06H
high-order position of data address	F0H
low-order position of data address	0AH
high-order position of information content	13H
low-order position of information content	88H
low-order position of CRC CHK	Wait to calculate the CRC CHK values
high-order position of CRC CHK	

Check way—CRC Check way: CRC (Cyclical Redundancy Check ) use RTU frame format,The message includes error detection field based on the method of CRC .CRC domain test the whole content of a message. CRC domain is two bytes, contains a 16-bit binary values.it is calculated by the transmission equipment, added to the message.receive messages the device recalculate.And compared with receives the CRC in the domain of value, if the two CRC value is not equal, then there is an error in transmission.

CRC is saved in 0xFFFF,Then call a process to continuous 8-bit bytes of the message and the values in the current register for

processing. Only 8 bit data in each character of CRC is effective, Starting bit and stopping bit and parity bits are invalid.

In the process of CRC, Each of the eight characters are separate and dissimilar or register contents (XOR) , The results move to the least significant bit direction, set the most significant bit to 0. LSB is extracted to test, if set LSB to 1, Register and preset value dissimilarity or alone, if set LSB to 0, is not to. The whole process will repeat 8 times. when the last time ( the eighth time) is completed, next 8-bit bytes and separate and register under the current value of the alien or. The values in the final register, Is all bytes in the message is executed after the CRC value.

When CRC added to the messages .The low byte to join first and then high byte. CRC Simple function is as follows:

```
unsigned int crc_cal_value(unsigned char *data_value, unsigned
char data_length)
```

```
{
int i;
unsigned int crc_value=0xffff;
while(data_length--)
{
crc_value^=*data_value++;
for(i=0;i<8;i++)
{
If(crc_value&0x0001)
crc_value=(crc_value>>1)^0xa001;
else
crc_value=crc_value>>1;
}
}
Return(crc_value);
}
```

Address definition of communication parameters

This part is the content of the communication, used to control the operation of the inverter, inverter status and related parameters setting. Read and write functional code parameter (some function code which can not be changed, only for the use of manufacturers or monitoring) : function code parameter address label rules:

By function block number and the label for the parameter address representation rules .High byte: F0~FF (P group) , A0~AF (C group) , 70~7F (D group) low byte: 00~FF

Such as: P3.12, The address is expressed as F30C; attention: PF group: Neither read the parameters, and do not change

parameters; Group D group: only can read, do not change the parameters.

When some parameters in converter is in operation, do not change; Some parameters of the frequency converter in any state, cannot be changed; Change function code parameters, but also pay attention to the range of parameters, units, and related instructions.

In addition, because the EEPROM is stored frequently, the service life of the block can reduce the the life of the block EPROM, so some function code under the mode of communication, do not need to be stored, just change the value of RAM. If it is P group of parameters, in order to realize the function, as long as putting this function code address high F into 0 can be achieved. If it is C group of parameters, in order to realize the function, as long as putting the function code the address of high A into 4 can be achieved. Corresponding function codes are shown as the following address: the high byte: 00 ~ 0F (P group), 40 ~ 4F (group B) low byte: 00 to FF

Such as:

Function code P3.12 is not stored in the EEPROM, The address is expressed as 030C; Function code C0-05 is not stored in the EEPROM, The address is expressed as 4005; The address representation can only do writing RAM, can't do reading action, when reading, it is invalid address. For all the parameters, can also use the command code 7H to implement this function.

Stopping/starting parameters:

Parameter address	Parameter description
1000	Communication Setting value (-10000~10000 ) (decimal system )
1001	Operating frequency
1002	Bus voltage
1003	output voltage
1004	current output
1005	output power
1006	output torque
1007	running velocity
1008	X Input Flag
1009	YO output Flag
100A	FIV voltage
100B	FIC voltage
100C	reserved
100D	count value input

100E	The length of the input
100F	The load speed
1010	PID setting
1011	PID feedback
1012	PLC steps
1013	PULSE the input pulse frequency,unit 0.01kHz
1014	Feedback speed, unit 0.1Hz
1015	The remaining running time
1016	FIV before correction voltage
1017	FIC before correction voltage
1018	reserved
1019	Linear velocity
101A	the current access to electricity time
101B	the current running time
101C	PULSE input pulse frequency,unit 1Hz
101D	Communication Setting value
101E	The actual speed of feedback
101F	The main frequency X show
1020	Auxiliary frequency Y show

**attention:**

Communication setting value is relative percentage, 10000 corresponds to 100.00% and - 10000-100.00%.The frequency of dimensional data, the percentage is relative to the percentage of maximum frequency (P012);Counter rotating torque dimensional data, the percentage is P2.10.

Control command input to the converter: (write-only )

The command word address	Command function
2000	0001: Running forward
	0002: Reverse running
	0003: normal inching turning
	0004: Reversal point move
	0005: Free downtime
	0006: Slowing down
	0007: Failure reset

Read the inverter state: (read-only)

Status word address	Status word function
3000	0001: Running forward
	0002: Reverse running
	0003: closing down

Parameters lock password check: (if return for 8888H,it indicates that the password check through)

Password address	The content of the Input password
1F00	*****

Command address	Command content
2001	BIT0: (reserve ) BIT1: (reserve ) BIT2: RA-RB-RC output control BIT3: YA-YB-YC output control BIT4: YO-R output control

Analog output FO1 control: (write-only)

Command address	Command content
2002	0~7FFF represent 0%~100%

Analog output FO2 control: (write-only )

Command address	Command content
2003	0~7FFFrepresent 0%~100%

PULSE (PULSE) output control: (write -only)

Command address	Command content
2004	0~7FFFrepresent 0%~100%

Frequency converter fault description:

Frequency converter fault address	Frequency converter fault information
-----------------------------------	---------------------------------------

8000	0000: failure-free 0001: Inverter unit protection 0002: Accelerate over current 0003: Slow down over current 0004: Constant speed over current 0005: Accelerate over the voltage 0006: Slow down over voltage 0007: Constant speed over voltage 0008: Buffer resistance overload fault 0009: Under-voltage fault 000A: The inverter overload 000B: Motor overload 000C: The input phase 000D: The output phase 000E: Module is overheating 000F: External fault 0010: Abnormal communication 0011: Abnormal contactor 0012: Current detection fault 0013: Motor tuning fault 0014: Encoder/PG card failure 0015: Abnormal parameters, reading and writing 0016: Inverter hardware failure 0017: Motor for short circuit fault 0018: reserved 0019: reserved 001A: Running time reached 001B: reserved 001C: reserved 001D: Accumulative power-on time reached
8000	001E: Load becoming 0 001F: PID feedback lost during running 0028: With-wave current limit fault 0029: Motor switchover fault during running 002A: Too large speed deviation 002B: Motor over-speed 002D: reserved 005A: Encoder line number setting error 005B: Don't connect the encoder 005C: Initial position fault 005E: Speed feedback error
Communication failures address	Fault feature description

8001	0000: failure-free 0001: Password mistake 0002: The command code error 0003: CRC Checking error 0004: Invalid address 0005: Invalid parameter 0006: correcting parameter is invalid 0007: System is locked 0008: Block is EEPROM operation
------	--

**PD group Communication parameters show**

PD.00	Baud rate	The factory value	0005
	setting range	units' digit:MODUBS Baud rate 0: 300BPS 1: 600BPS 2: 1200BPS 3: 2400BPS 4: 4800BPS 5: 9600BPS 6: 19200BPS 7: 38400BPS 8: 57600BPS 9: 115200BPS	

This parameter is used to set data transfer rate between the PC and inverter. Notice that setting the baud rate of upper machine and converter must agree, otherwise, the communication can't carry on. The faster the baud rate, the greater the communication.

PD.01	The data format	The factory value	3
	setting range	0: No check: The data format<8,N,2> 1: even-parity: The data format<8,E,1> 2: odd parity check: The data format<8,O,1> 3: No check: The data format<8-N-1>	

PC and data format set by the frequency converter must agree, otherwise, the communication can't carry on.

PD.02	The machine address	The factory value	1
	setting range	1~247, 0 is the broadcast address	

When the machine address set to 0, namely for the broadcast address, realize PC broadcasting functions.

The machine address has uniqueness (except the broadcast address), which is to achieve the basis of upper machine and inverter peer-to-peer communications.

PD.03	Response latency	The factory value	2ms
	setting range	0~20ms	

Response latency: refers to the frequency converter data to accept the end up to a upper machine to send data in the middle of the interval of time.If the response time delay is less than the system processing time, the response time delay will be subject to system processing time, processing time, such as response time delay is longer than system after processing the data, the system will delay waiting, until the response delay time to up to a upper machine to send data.

PD.04	Communication timeout	The factory value	0
	setting range	0.0 s (invalid ) 0.1~60.0s	

When the function code is set to 0.0 s, communication timeout parameter is invalid.

When the function code set to valid values, if a communication and the interval time of the next communication beyond the communication timeout, system will be submitted to the communication failure error (E16).Usually, it is set into is invalid.If, in the continuous communication system parameter set the time, you can monitor the communication status.

PD.05	Communication protocol selection	The factory value	1
	setting range	0: Non standard Modbus protocol 1: The standard Modbus protocol	

PD.05=1: choose the standard Modbus protocol

PD.05=0: when reading command ,Returns number of bytes from the machine is a byte more than the standard Modbus protocol, detailed in this agreement 5 Communication data structures.

PD.06	Read the current resolution	The factory value	1
	setting range	0: 0.01A 1: 0.1A	

Used to determine the communication while reading the output current, current value of the output units.

## Appendix C

# Profibus-DP application protocol and instructions for use

(Version number: V2.2)

### 1. Scope

This instruction specifies the user data format and protocol between Profibus card and master communication, the protocol content used in communication between the inverter and data exchange.

### 2. Terms and definitions, abbreviations

CRC—Cyclic Redundancy Check

RS485—Bidirectional half-duplex communication protocol

### 3. Agreement basis

According to the GSD document requirements, two sets of 16Bytes are defined, one set is inverter control data and the other set is inverter status data (read-only), which are described as follows:

Master downlink data format description (master issued):

Master → Inverter (Inverter Control Data):

Start Byte	Field	Number of bytes	Description and Requirements
0~3	PKW1~PKW4	4Byte	parameter area, undefined, the default is 0
4	CW	1Byte	Control word, bit is defined as follows, 0 means invalid, 1 means valid: Bit0-Bit2: 1 Forward running, 2 Reverse running 3 Forward jog 4 Reverse jog 5 Free stop 6 Deceleration stop 7 Fault reset Bit3-Bit7: Reserved
5	SW	1Byte	—
6~7	PZD2	2Byte	Speed given percentage, 10000 corresponds to 100% of rated frequency Range: 1 ~ 10000

## Appendix C Profibus-DP application protocol and instructions for use

Start Byte	Field	Number of bytes	Description and Requirements
8-9	PZD3	2Byte	Torque digital setting -200.0%~200.0%
10-11	PZD4	2Byte	Rated frequency setting, 2 decimal places; If 10000 means setting 100hz
12-13	PZD5	2Byte	Reserved
14-15	PZD6	2Byte	Reserved

Inverter upstream data description (uploaded from device):

Inverter -> Master (Inverter status data):

Start Byte	Field	Number of bytes	Description and Requirements
0-3	PKW1~PKW4	4Byte	Undefined, the default is 0
4	CW	1Byte	-
5	SW	1Byte	Status word, bit is defined as follows, 0 means invalid, 1 means valid: Bit0-Bit1: 1 forward running 2 Reverse run 3 OFF state Bit2 ~ Bit5: 0 No breakdown 1 inverter unit failure 2 Accelerate overcurrent 3 deceleration over-current 4 constant speed over current 5 Accelerate over voltage 6 decelerate over voltage 7 constant speed over voltage 8 buffer resistance overload 9 Undervoltage fault 0A inverter overload 0B Motor overload 0C input phase loss 0D output phase loss 0E module overheated 0F External fault Bit6 ~ Bit7: reserved
6-7	PZD2	2Byte	Operating frequency, unit: Hz 2 decimal places, such as 100000 indicates the current running frequency 100.0Hz
8-9	PZD3	2Byte	Output voltage in V Resolution: 0.1V / Bit

Start Byte	Field	Number of bytes	Description and Requirements
10~11	PZD4	2Byte	Output current, unit: A. Resolution: 0.1A / Bit
12~13	PZD5	2Byte	Reserved
14~15	PZD6	2Byte	Reserved (Heartbeat)

Note: double-byte data high in the former, low post

#### 4. Configure the parameters

1) ID: 8

2) Profibus card slave address: 3

3) Profibus communication baud rate self -adaptive

4) The inverter parameters need to be configured as communication control mode, the configuration parameters are as follows:

P0.02: 2 (communication instruction channel)

P0.04: 9 (the main frequency is given by original communication, P0.03 need to be changed to 0)

PD.00: 4005 (Note that after this parameter been set, it would be effective only after power off and re-start)

PD.02: 1 (local address)

#### 5. Module instructions

1) address configuration; the default 8-bit DIP switches are in OFF state (dial down), the default address is 3;

When you need to change the address, the DIP codes 1 ~ 4 are valid. The DIP code 1 controls bit0. The DIP code 2 means bit1. The DIP code 3 means bit2. The DIP code 4 means bit3. The maximum value can be 0x0F (one byte). Note that after changing the address, it must be powered on again then can be effective.

2) Working indicator light; after power on if work normally, green light would be on, the yellow light is on when the connection with the master station is successful, and the red light flashes when there is data interaction with the master station.



